

INDEX OF WIRING DIAGRAMS

DIAGRAM 1	Sample Diagram: How To Read & Interpret Wiring Diagrams
DIAGRAM 2	Sample Diagram: Wiring Diagram Symbols
DIAGRAM 3	1984 5.7L TBI VIN 8 Engine Schematic
DIAGRAM 4	1985-89 5.7L TPI VIN 8 Engine Schematic
DIAGRAM 5	1990 5.7L TPI VIN 8 Engine Schematic
DIAGRAM 6	1991 5.7L TPI VIN 8 Engine Schematic
DIAGRAM 7	1990-95 5.7L MFI VIN J Engine Schematic
DIAGRAM 8	1992-95 5.7L MFI VIN P Engine Schematic
DIAGRAM 9	1996 5.7L MFI Engine Schematic (Page 1 of 2)
DIAGRAM 10	1996 5.7L MFI Engine Schematic (Page 2 of 2)
DIAGRAM 11	1984-85 Starting, Charging, Fuel Pump, Cooling Fans Chassis Schematics
DIAGRAM 12	1986-88 Starting, Charging, Fuel Pump Chassis Schematics
DIAGRAM 13	1984-89 Cooling Fans, '89 Charging, 84-89 Horns Chassis Schematics
DIAGRAM 14	1989-92 Starting, Charging Chassis Schematics
DIAGRAM 15	1993-96 Starting, Charging Chassis Schematics
DIAGRAM 16	1984-88 Headlights, Headlight Doors, Back-up Lights Chassis Schematics
DIAGRAM 17	1989 Headlights, Headlight Doors, Back-up Lights Chassis Schematics
DIAGRAM 18	1984-85 Parking/Marker Lights, Turn/Hazard Lights Chassis Schematics
DIAGRAM 19	1986-89 Parking/Marker Lights, Turn/Hazard Lights Chassis Schematics
DIAGRAM 20	1990-96 Headlights w/o DRL, Headlight Doors, Headlights w/DRL Chassis Schematics
DIAGRAM 21	1990-96 Turn/Hazard Lights Chassis Schematics
DIAGRAM 22	1990-96 Parking/Marker Lights, Back-up Lights, Stop Lights Chassis Schematics
DIAGRAM 23	1990-96 Fuel Pump Chassis Schematics
DIAGRAM 24	1990-96 Cooling Fans, Horns Chassis Schematics
DIAGRAM 25	1994-95 Cooling Fans, Horns Chassis Schematics
DIAGRAM 26	1984-96 Windshield Wiper/Washer Chassis Schematics

WIRING DIAGRAM SYMBOLS

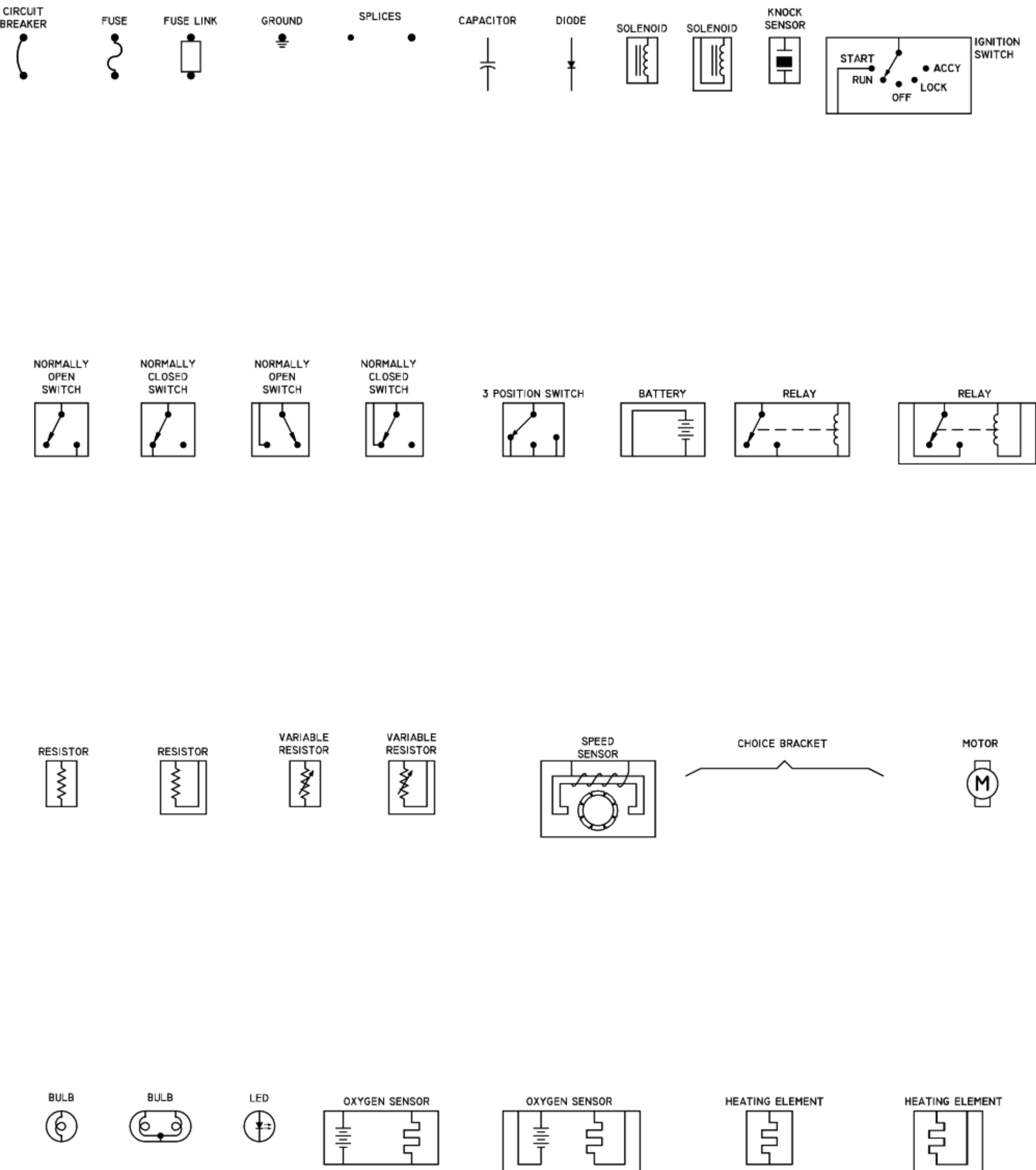

DIAGRAM 2

1990 5.7L TPI VIN 8 ENGINE SCHEMATIC

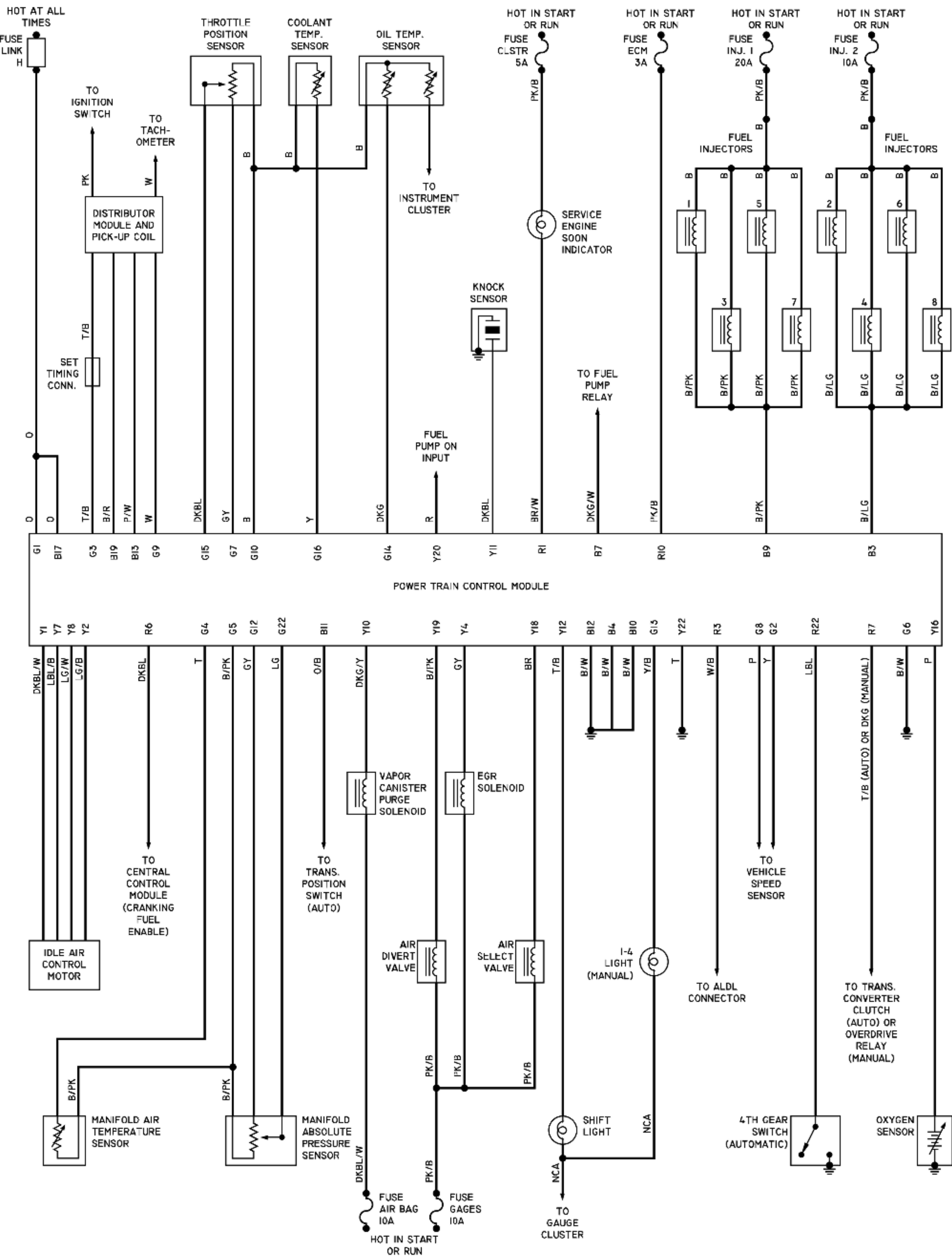

DIAGRAM 5

1991 5.7L TPI VIN 8 ENGINE SCHEMATIC

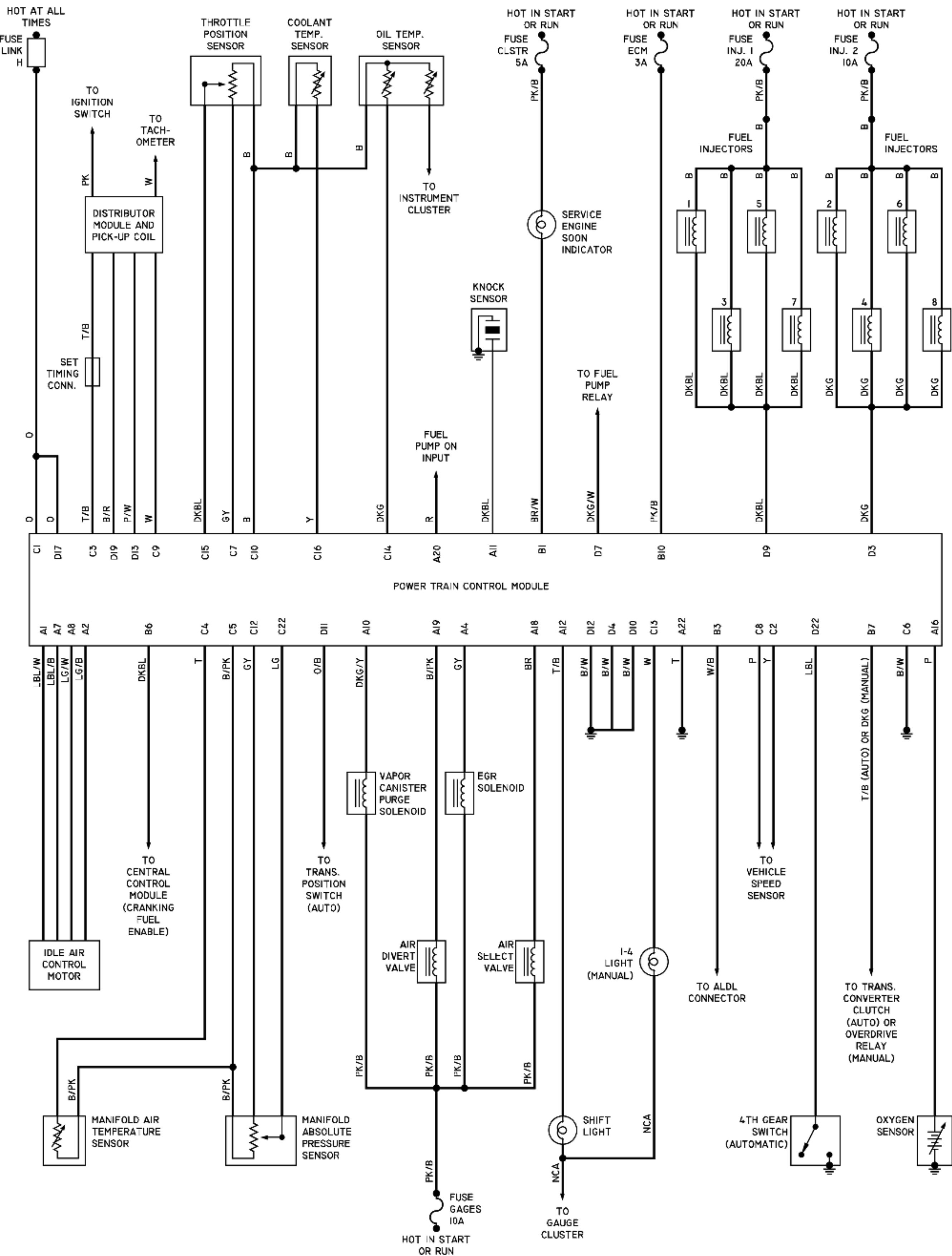

DIAGRAM 6

1990-1995 5.7L MFI VIN J ENGINE SCHEMATIC

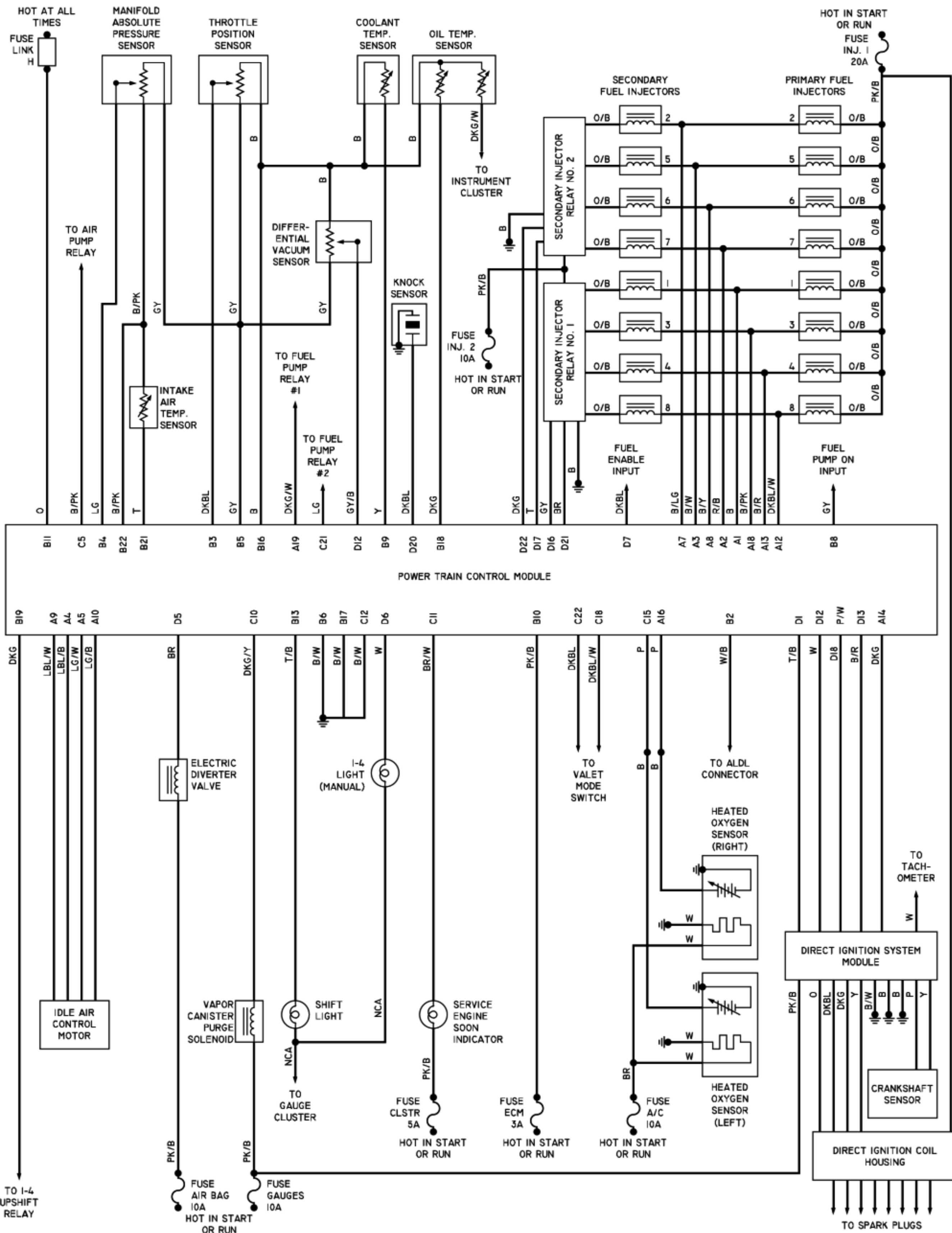

DIAGRAM 7

1992-95 5.7L MFI VIN P ENGINE SCHEMATIC

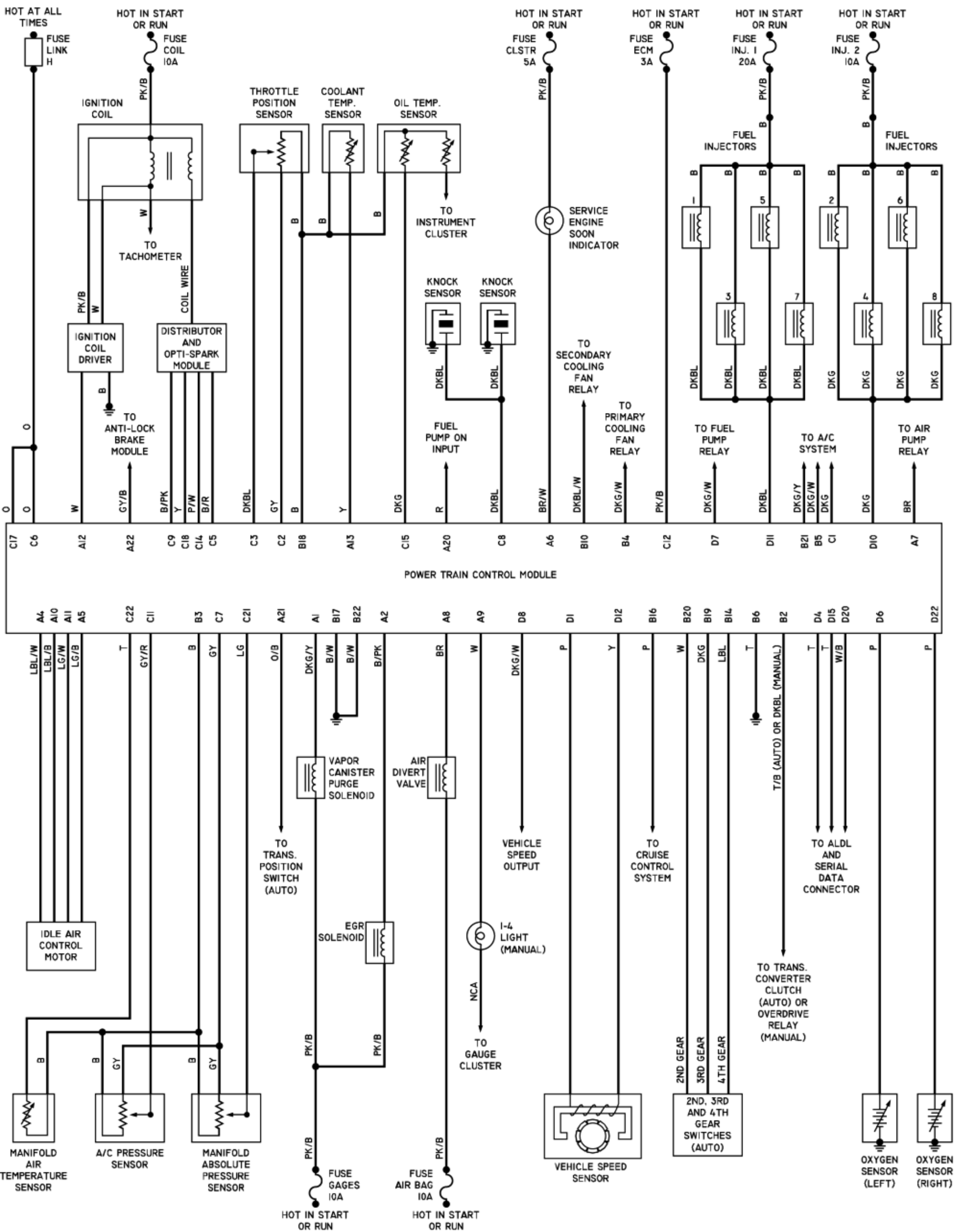

DIAGRAM 8

1996 5.7L MFI ENGINE SCHEMATIC (PAGE 1 OF 2)

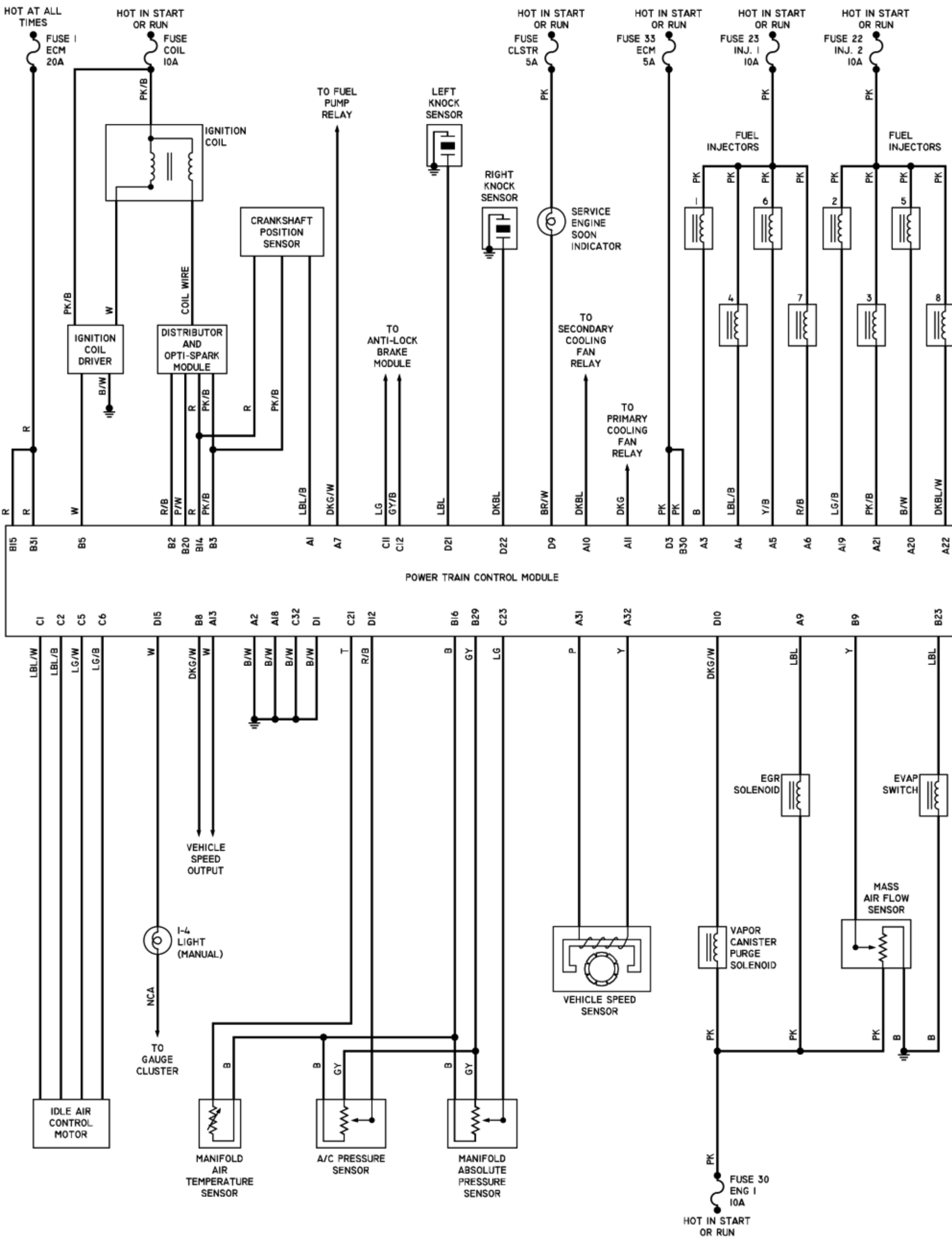

DIAGRAM 9

1996 5.7L MFI ENGINE SCHEMATIC (PAGE 2 OF 2)

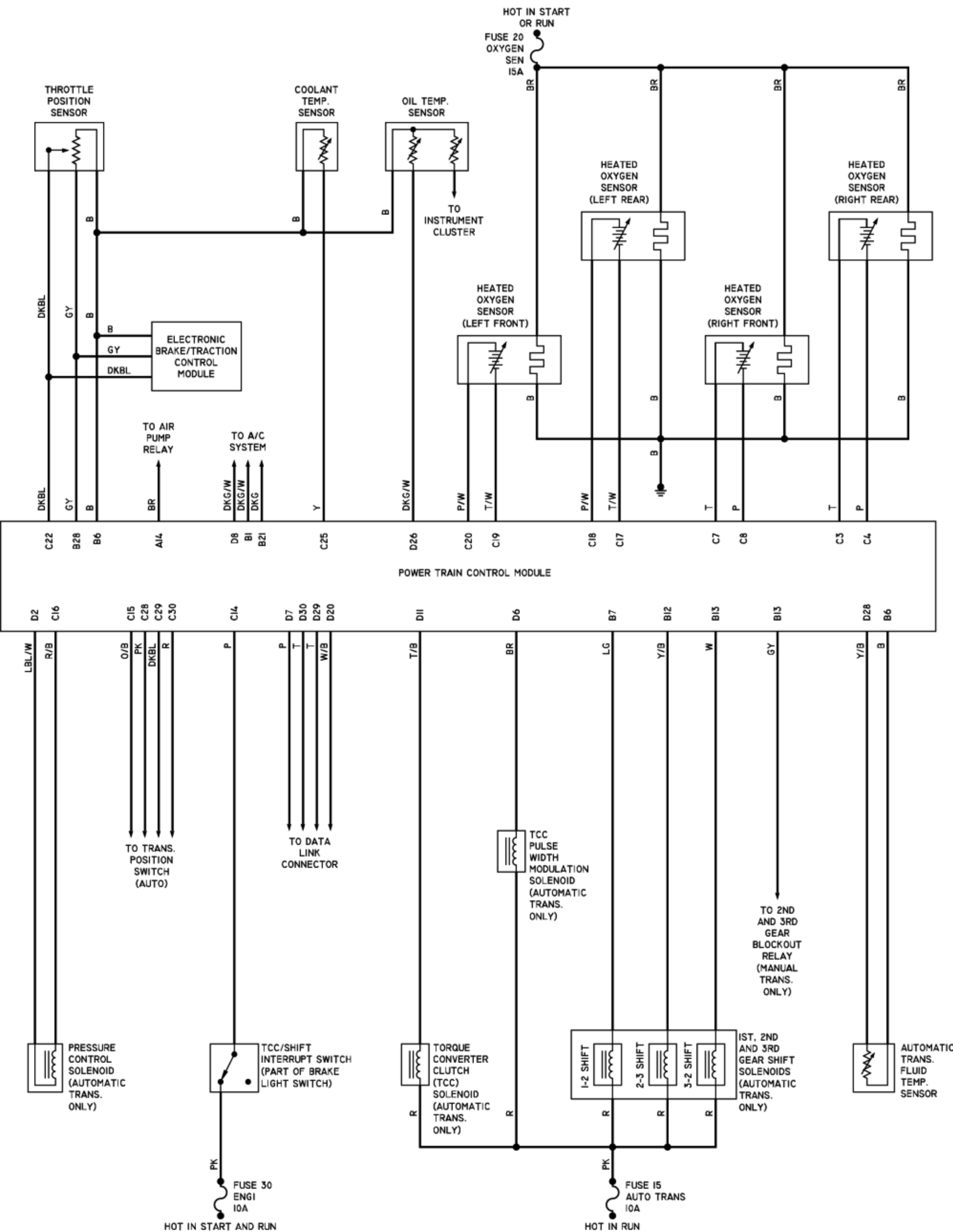

DIAGRAM 10

1984-85 CORVETTE CHASSIS SCHEMATIC

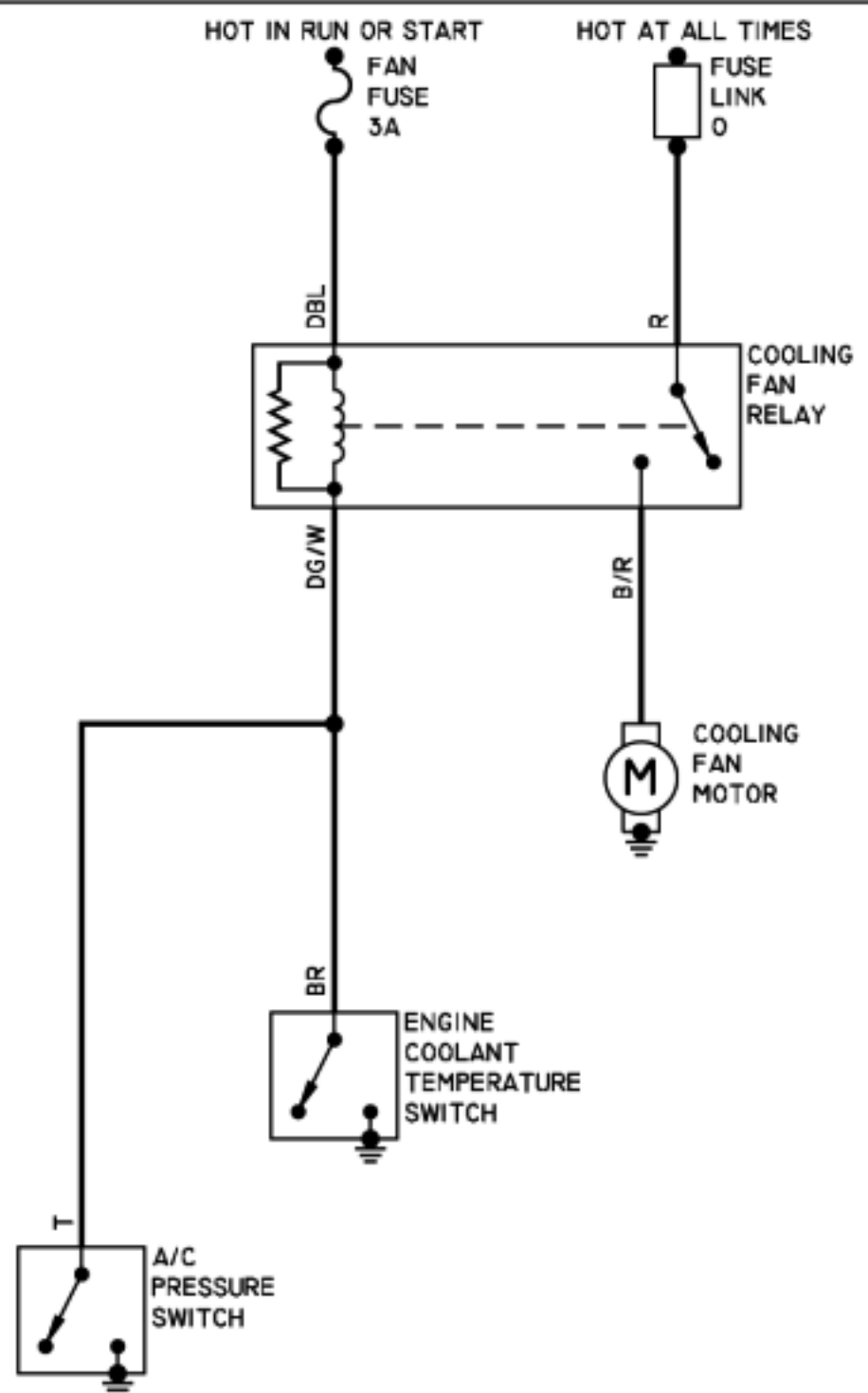
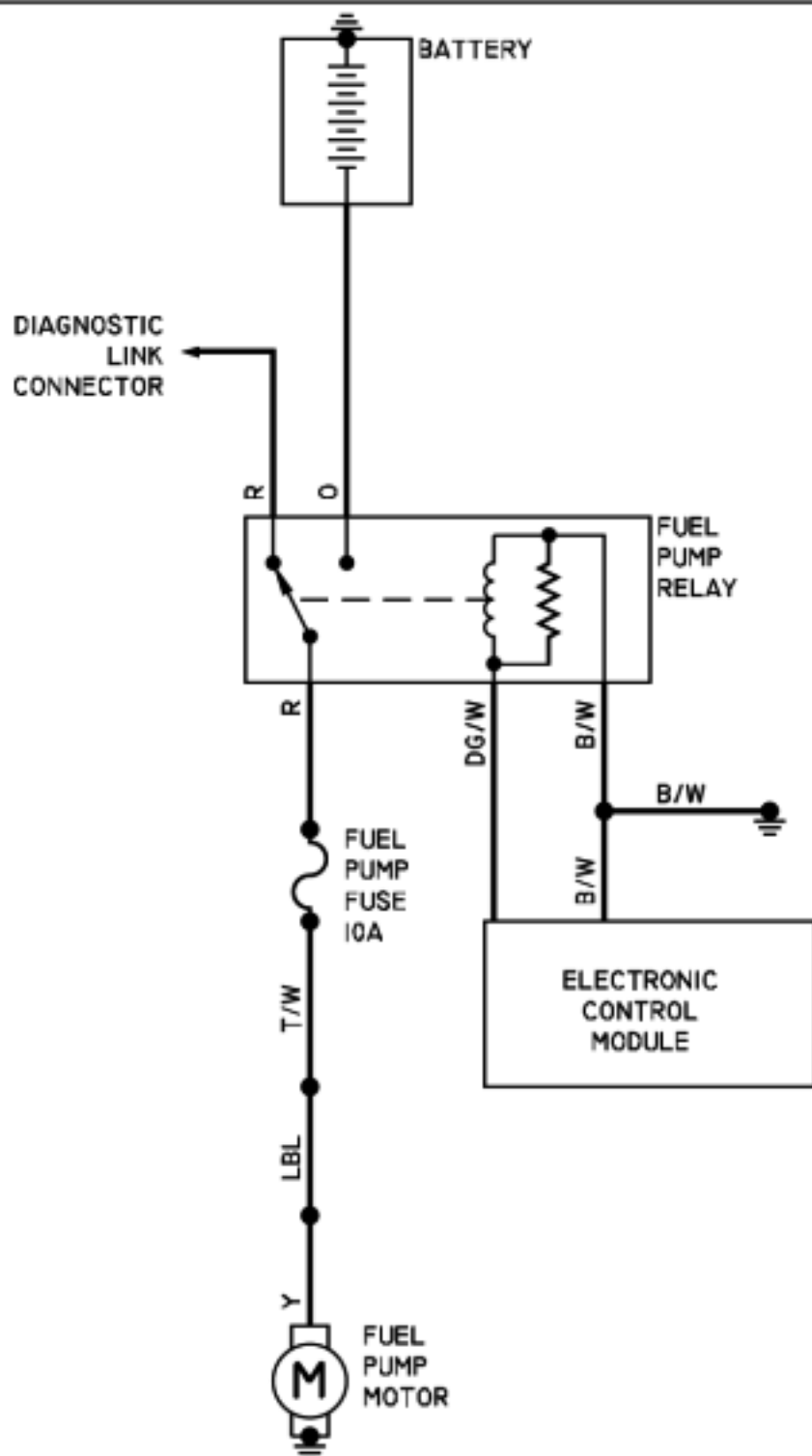
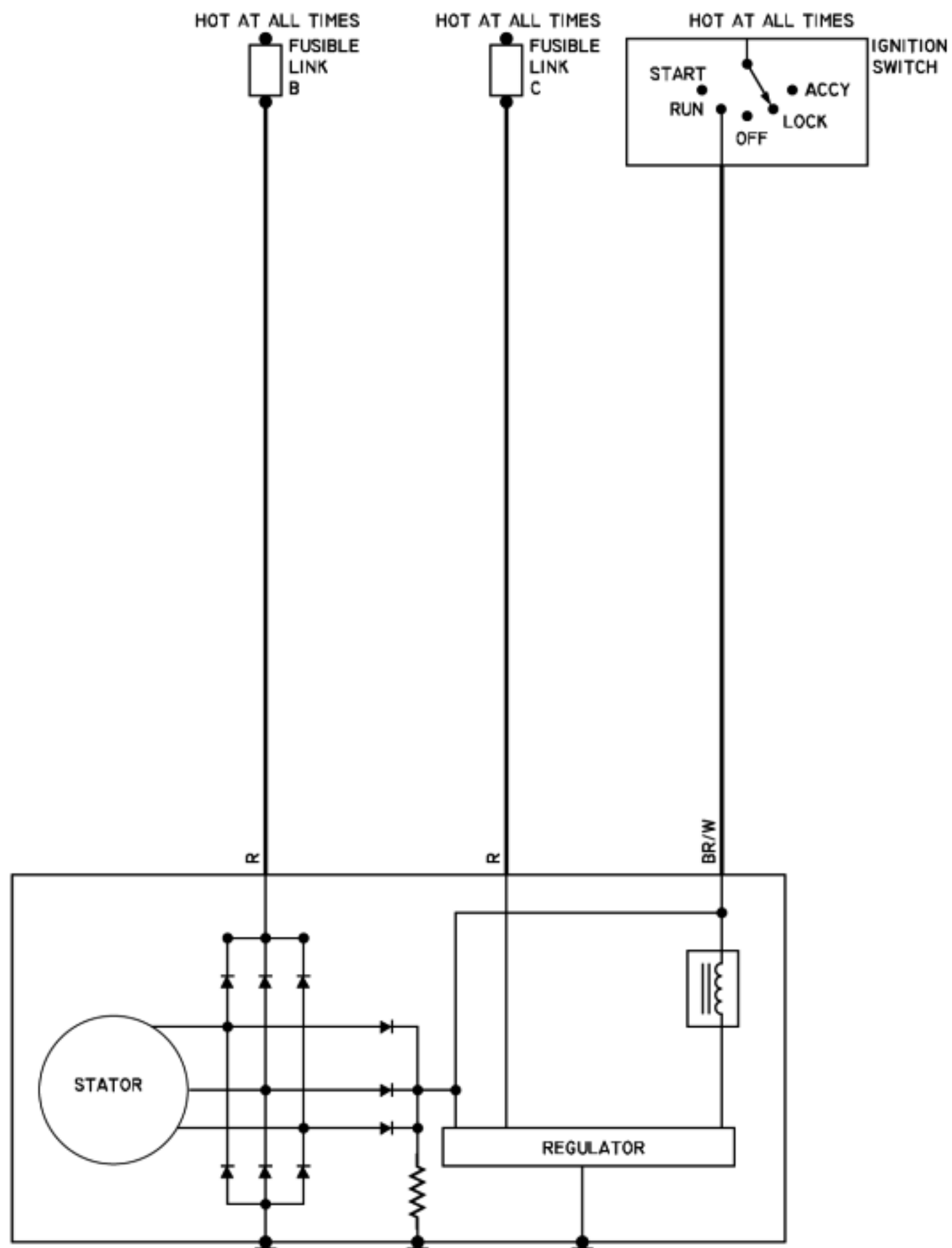
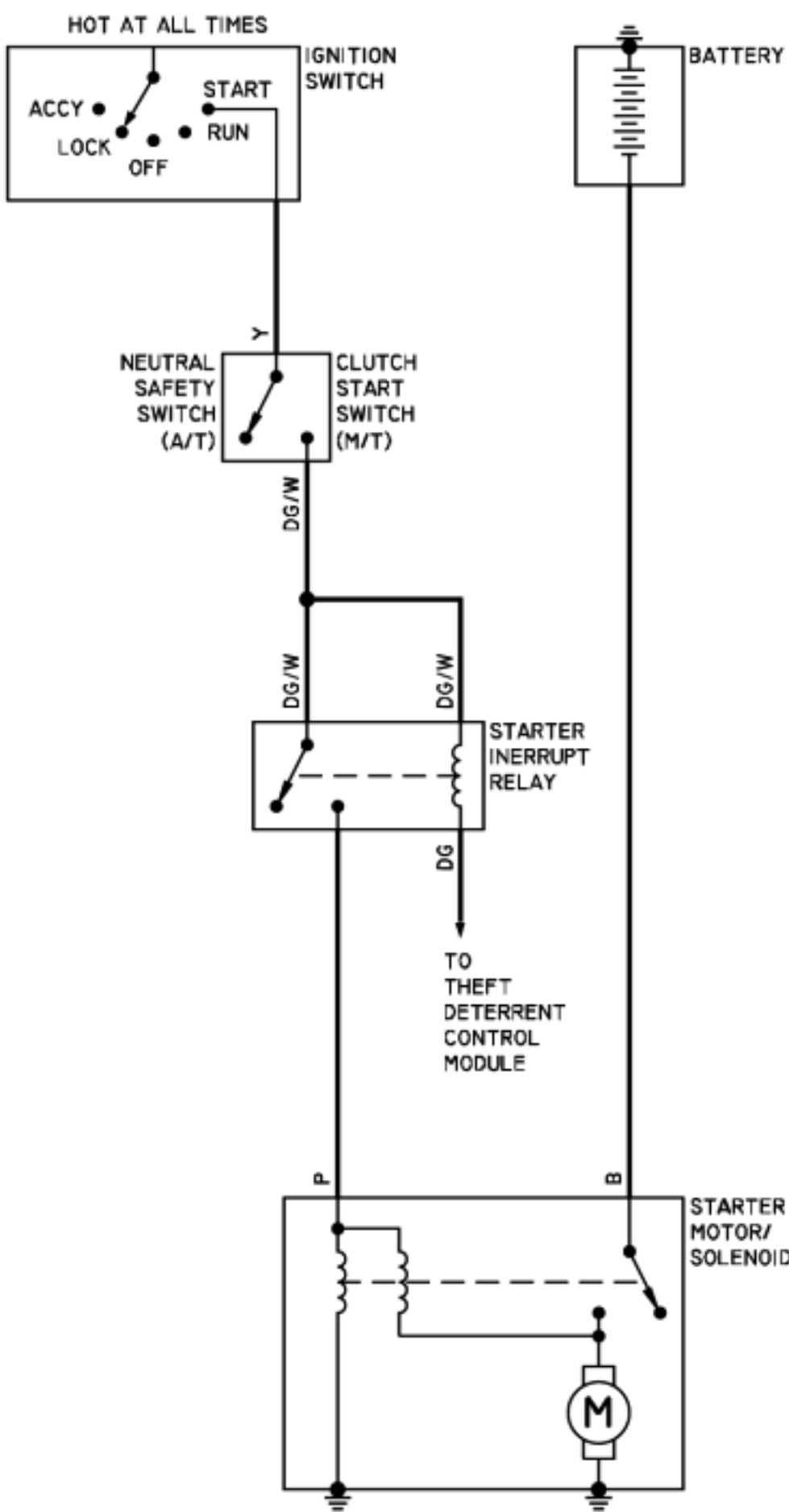

DIAGRAM 11

1986-88 CORVETTE CHASSIS SCHEMATIC

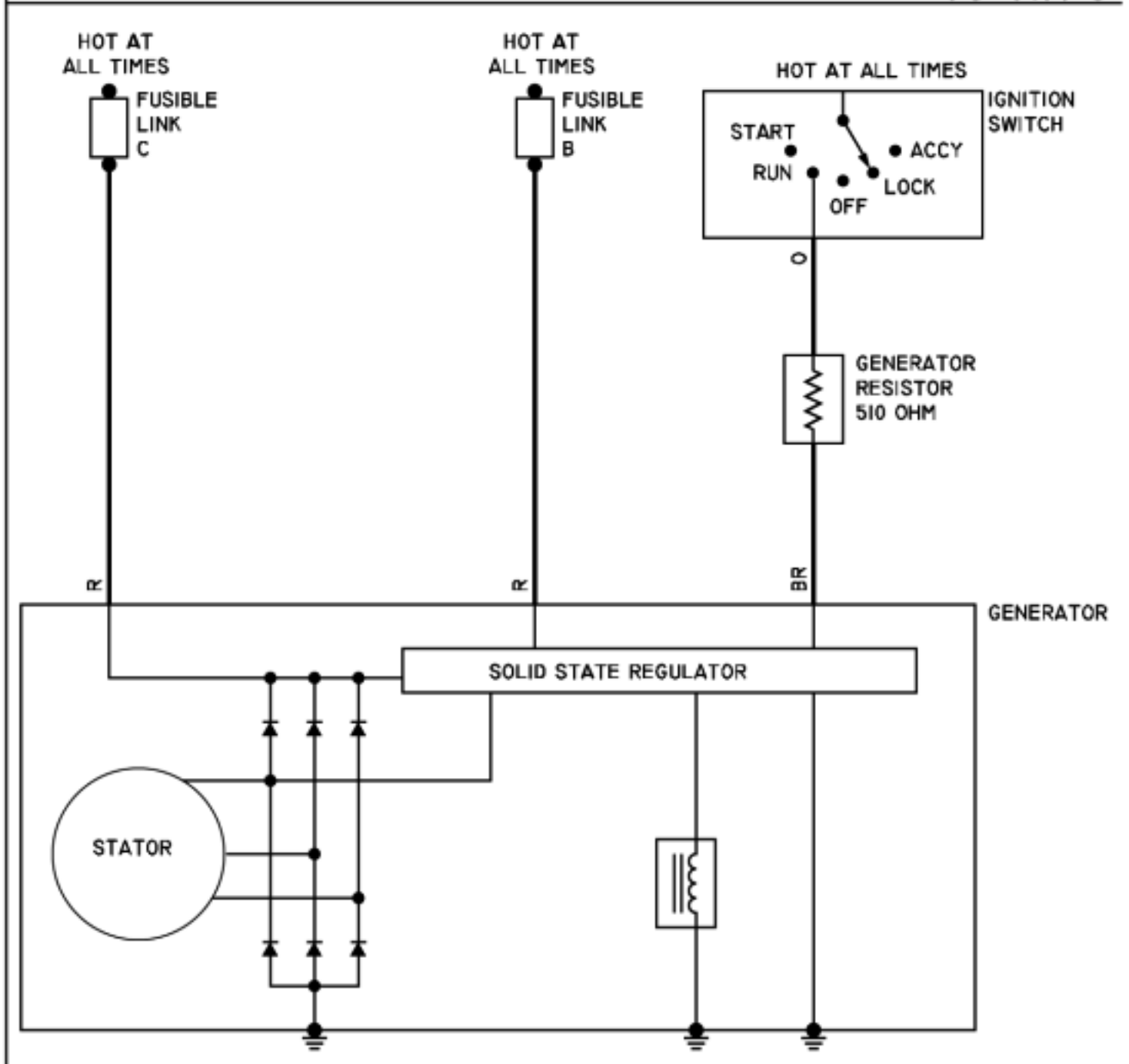
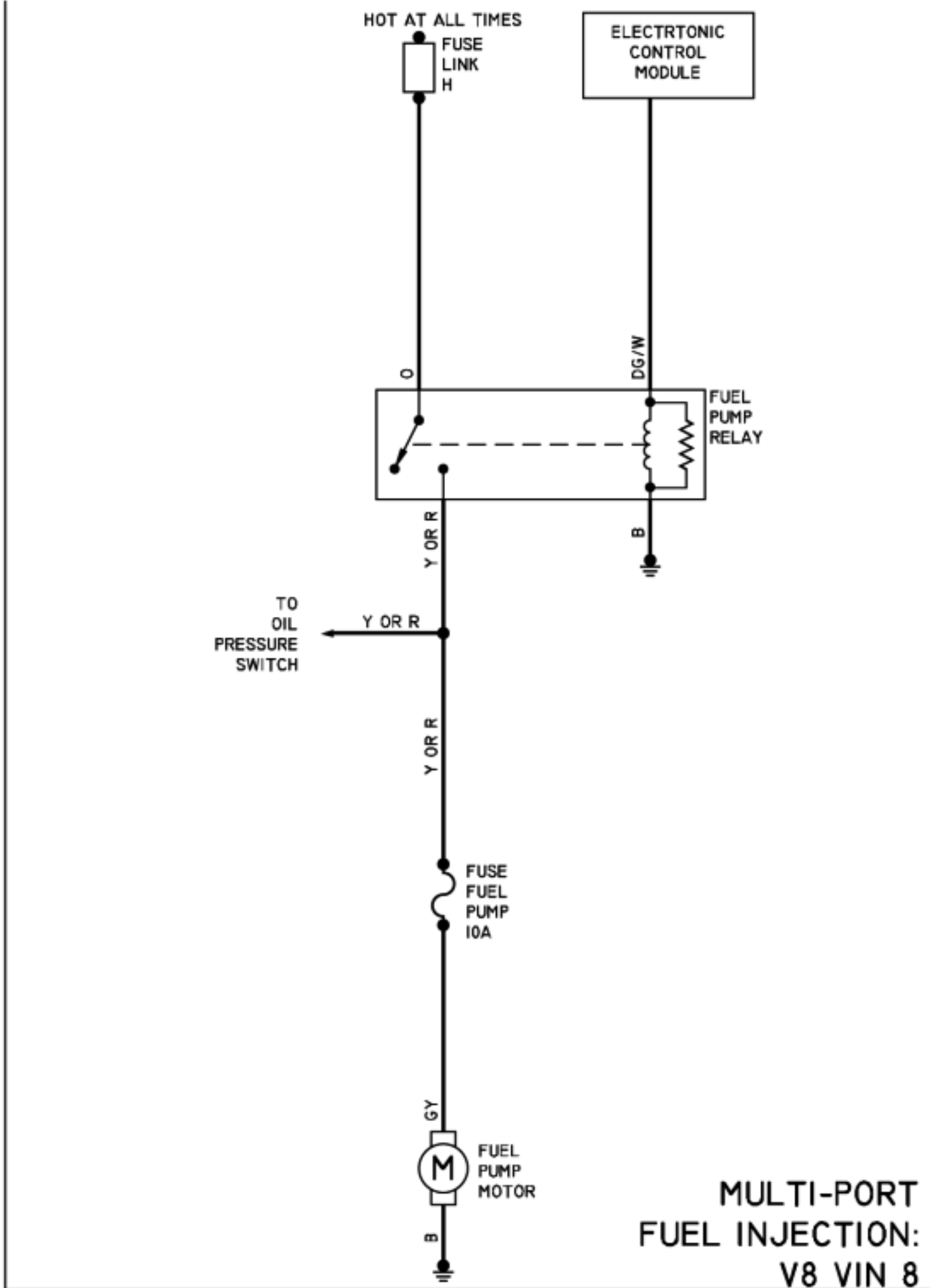
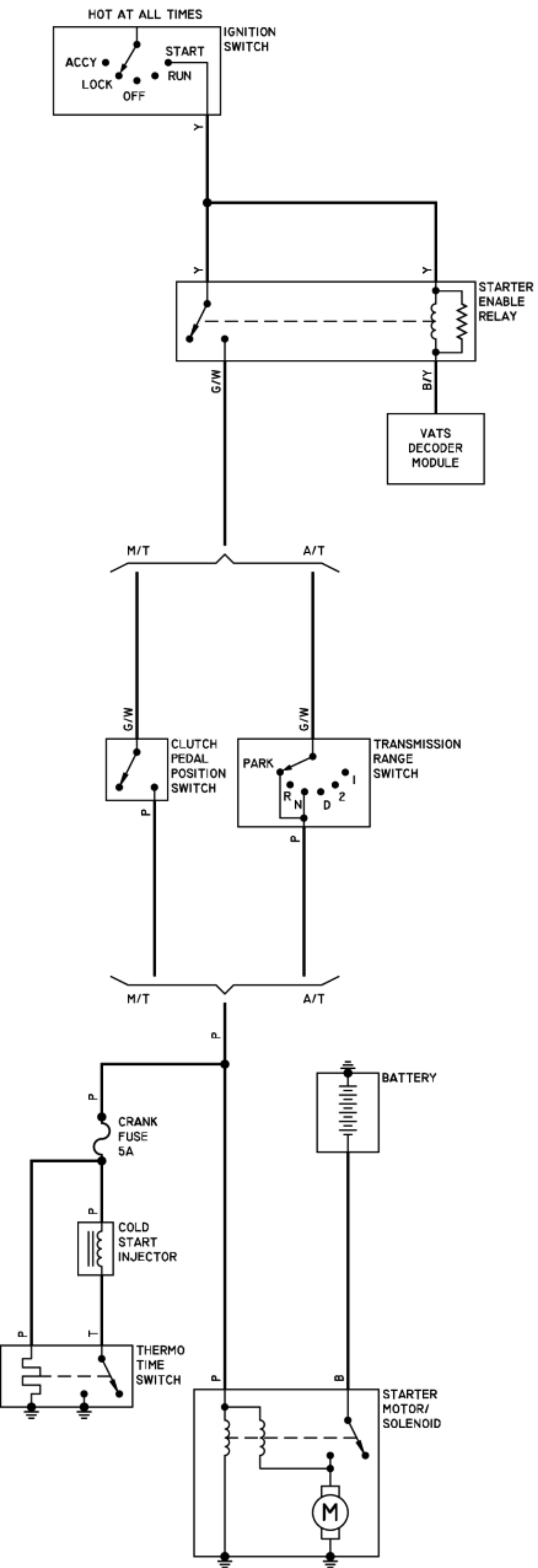

DIAGRAM 12

1984-89 CORVETTE CHASSIS SCHEMATIC

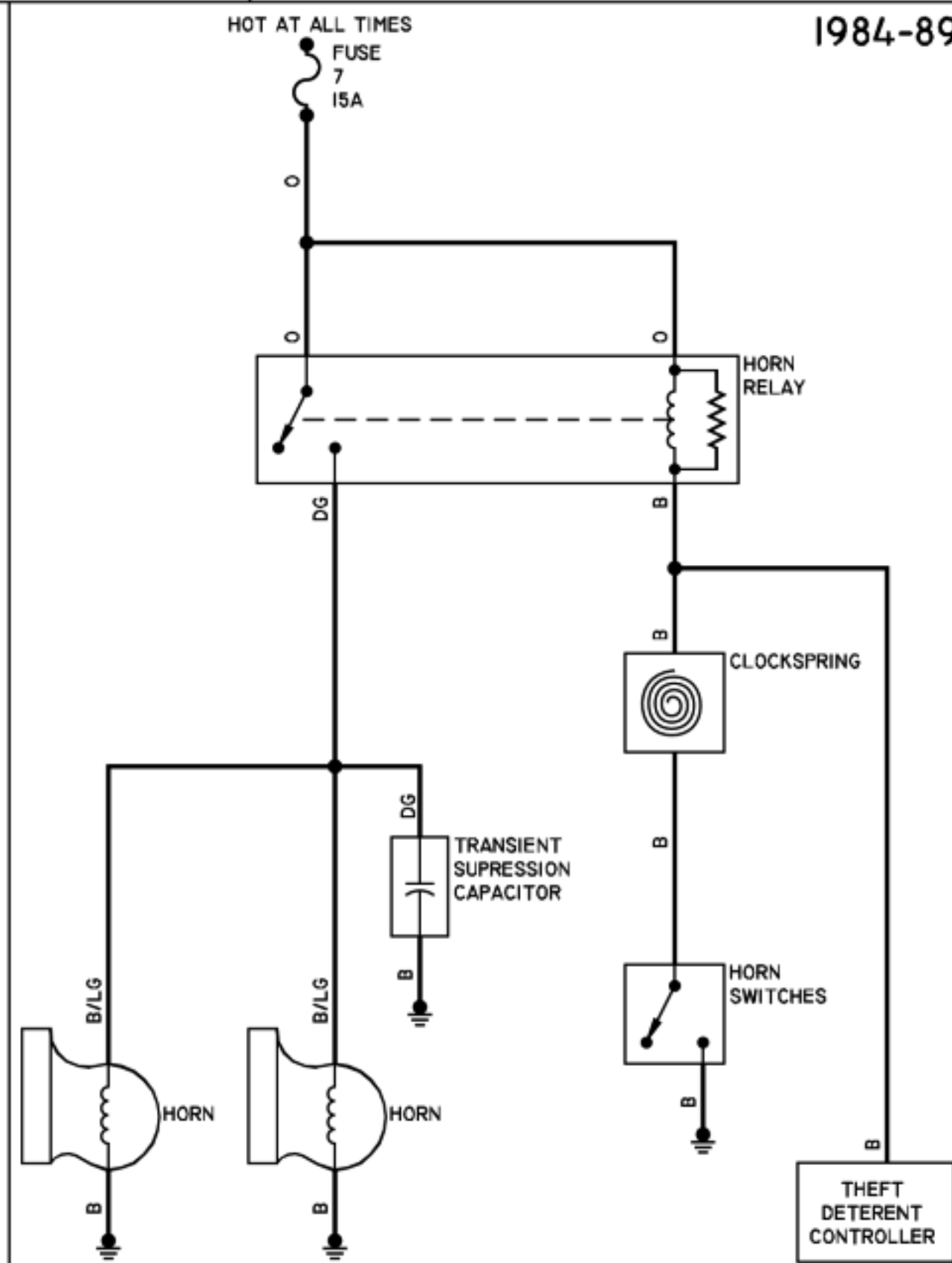
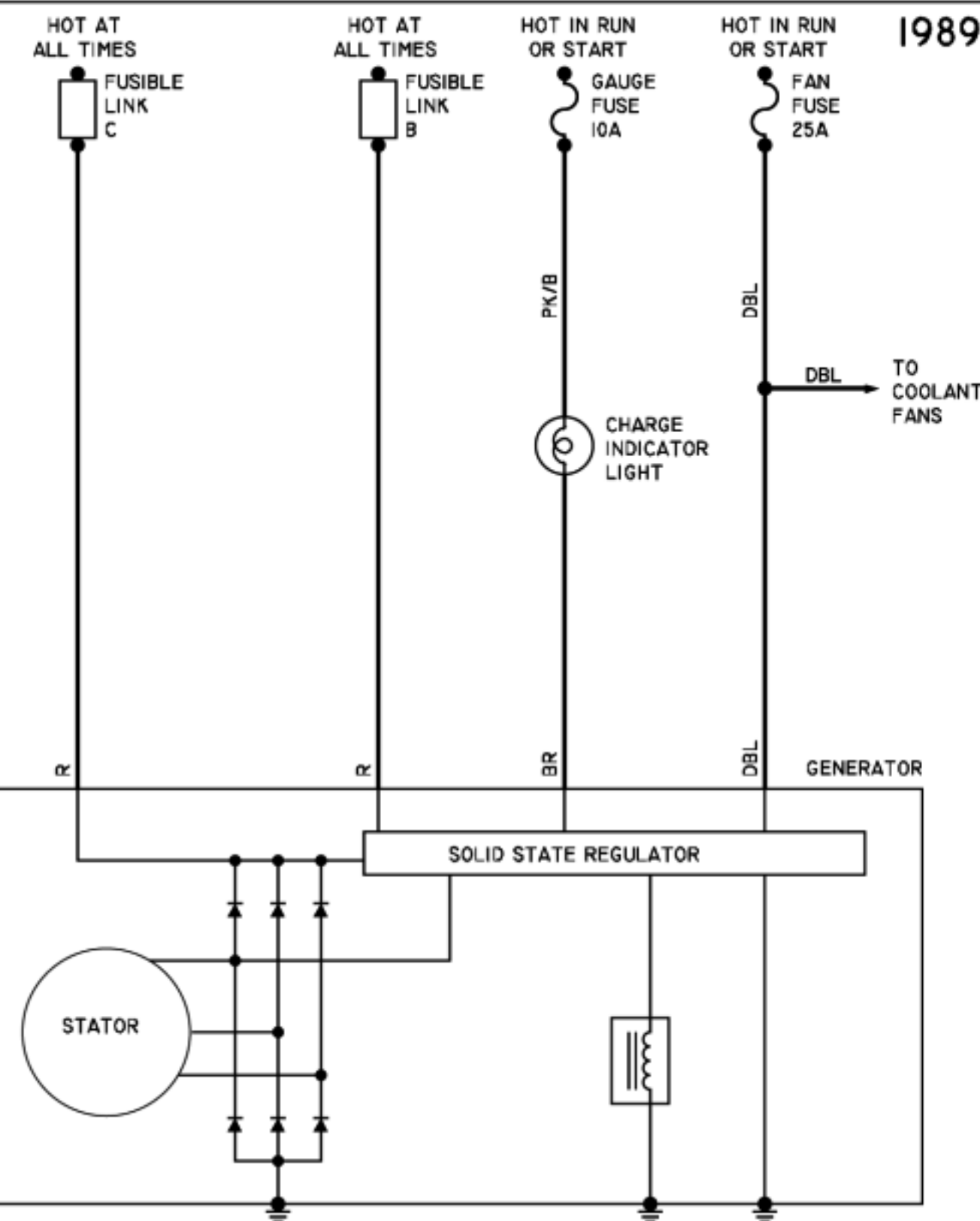
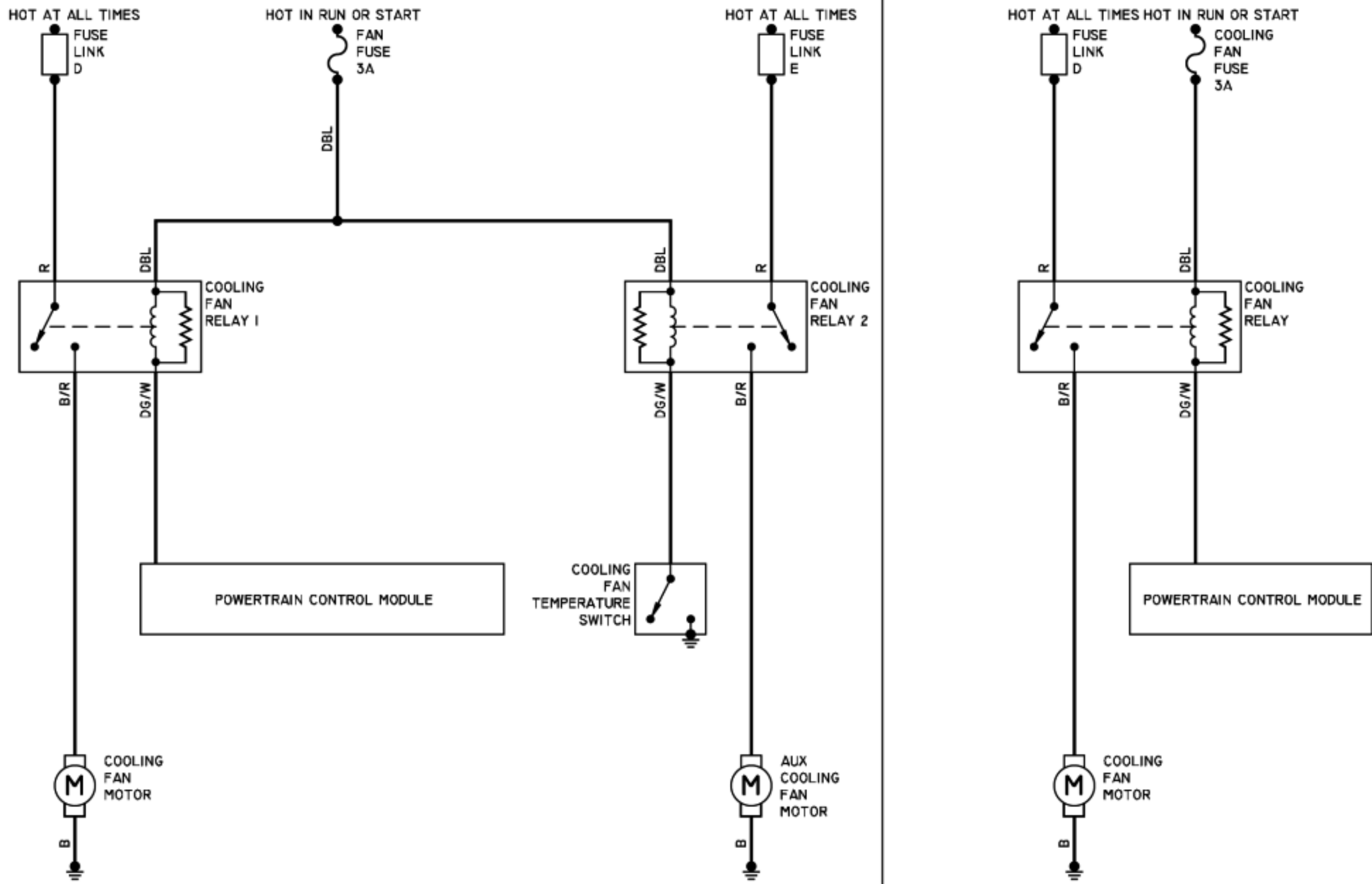

DIAGRAM 13

1993-96 CORVETTE CHASSIS SCHEMATIC

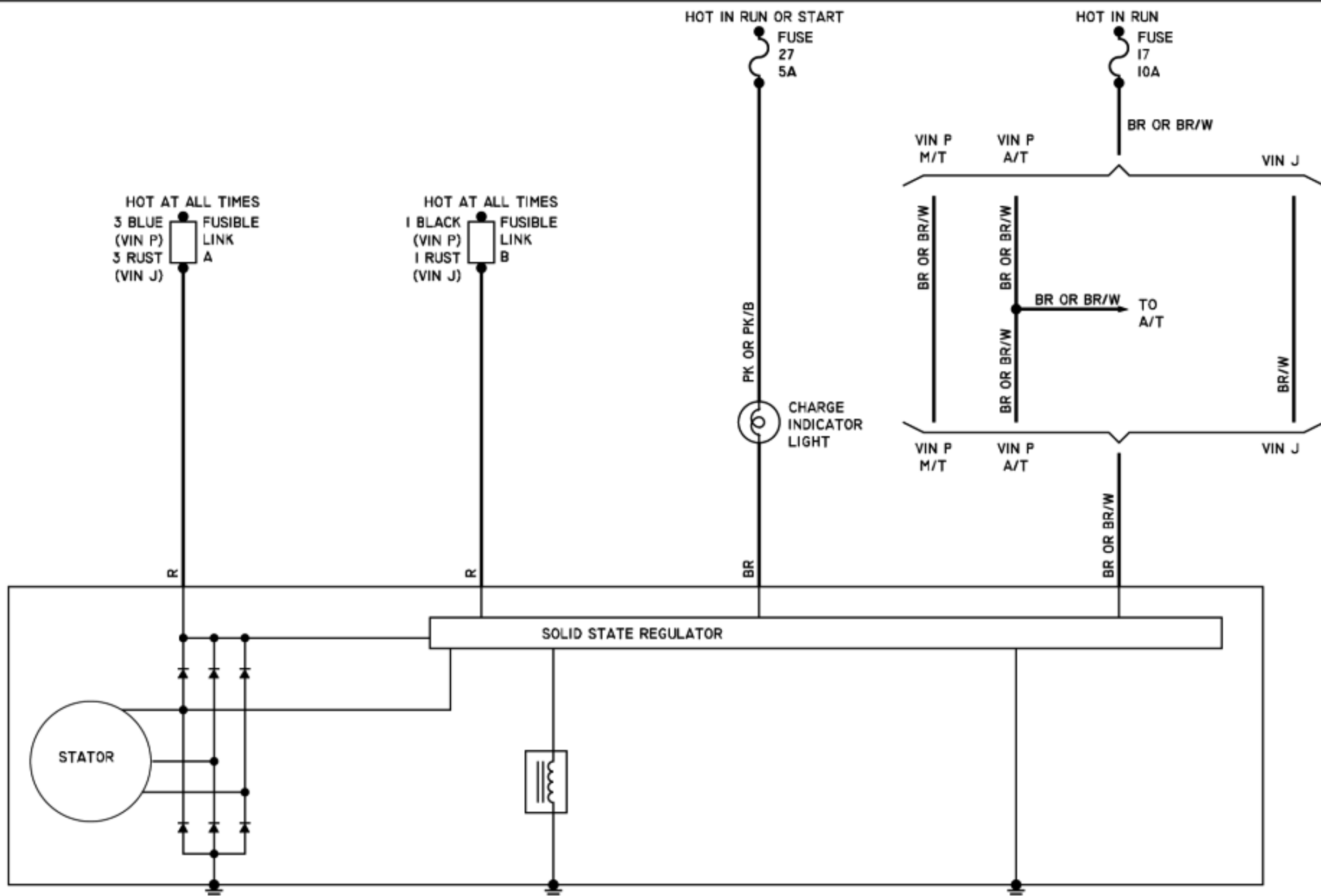
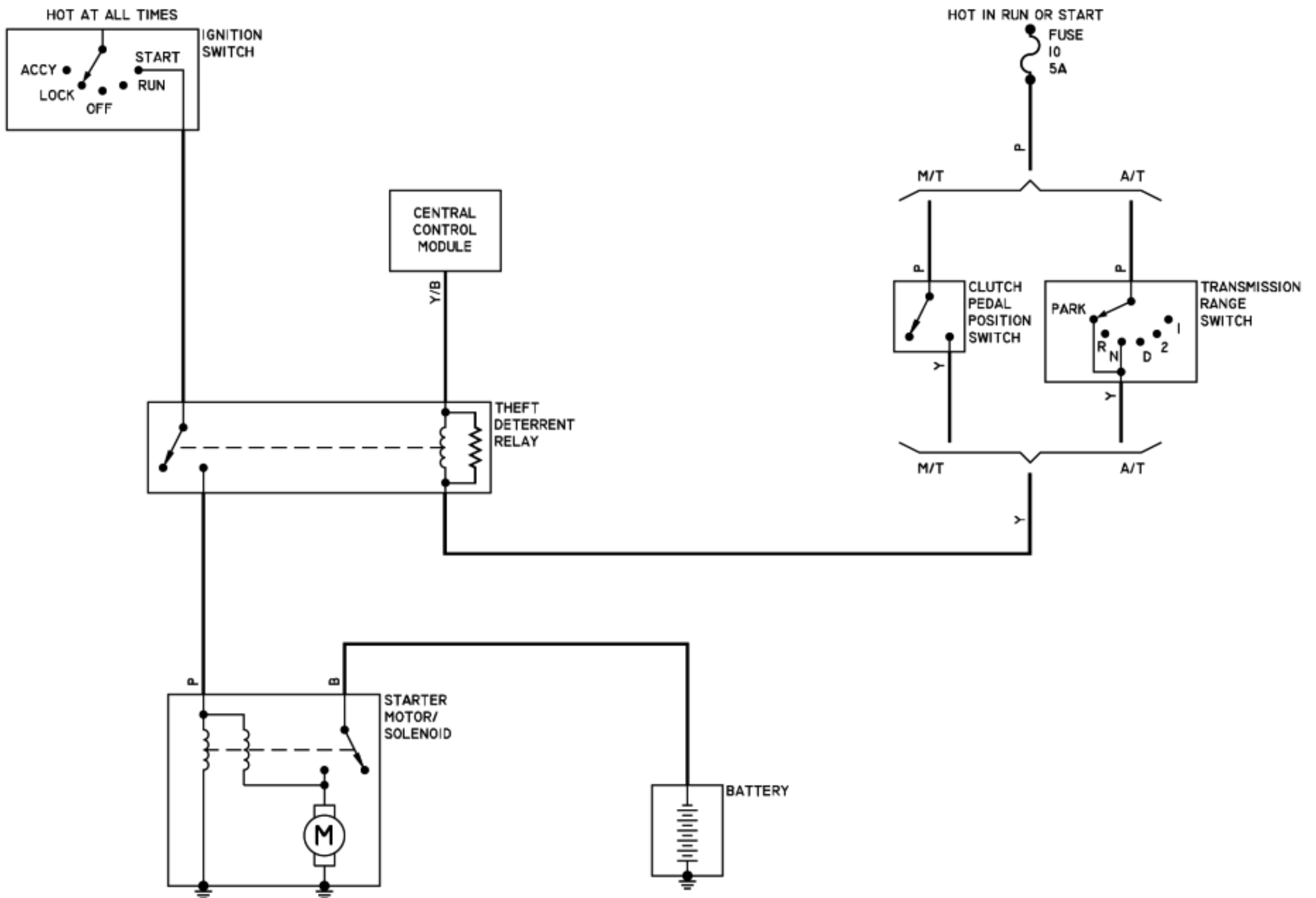

DIAGRAM 15

1984-88 CORVETTE CHASSIS SCHEMATIC

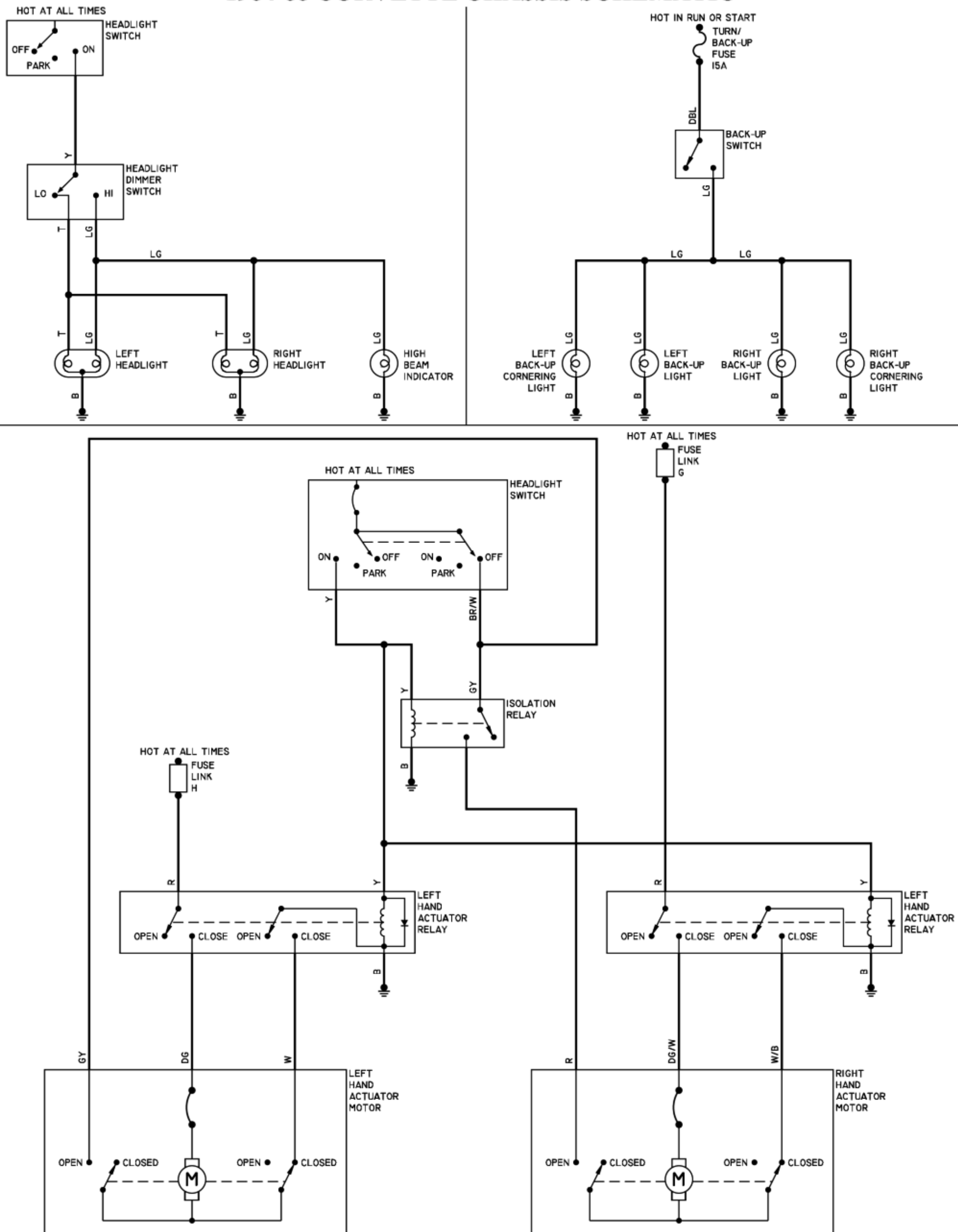

DIAGRAM 16

1989 CORVETTE CHASSIS SCHEMATIC

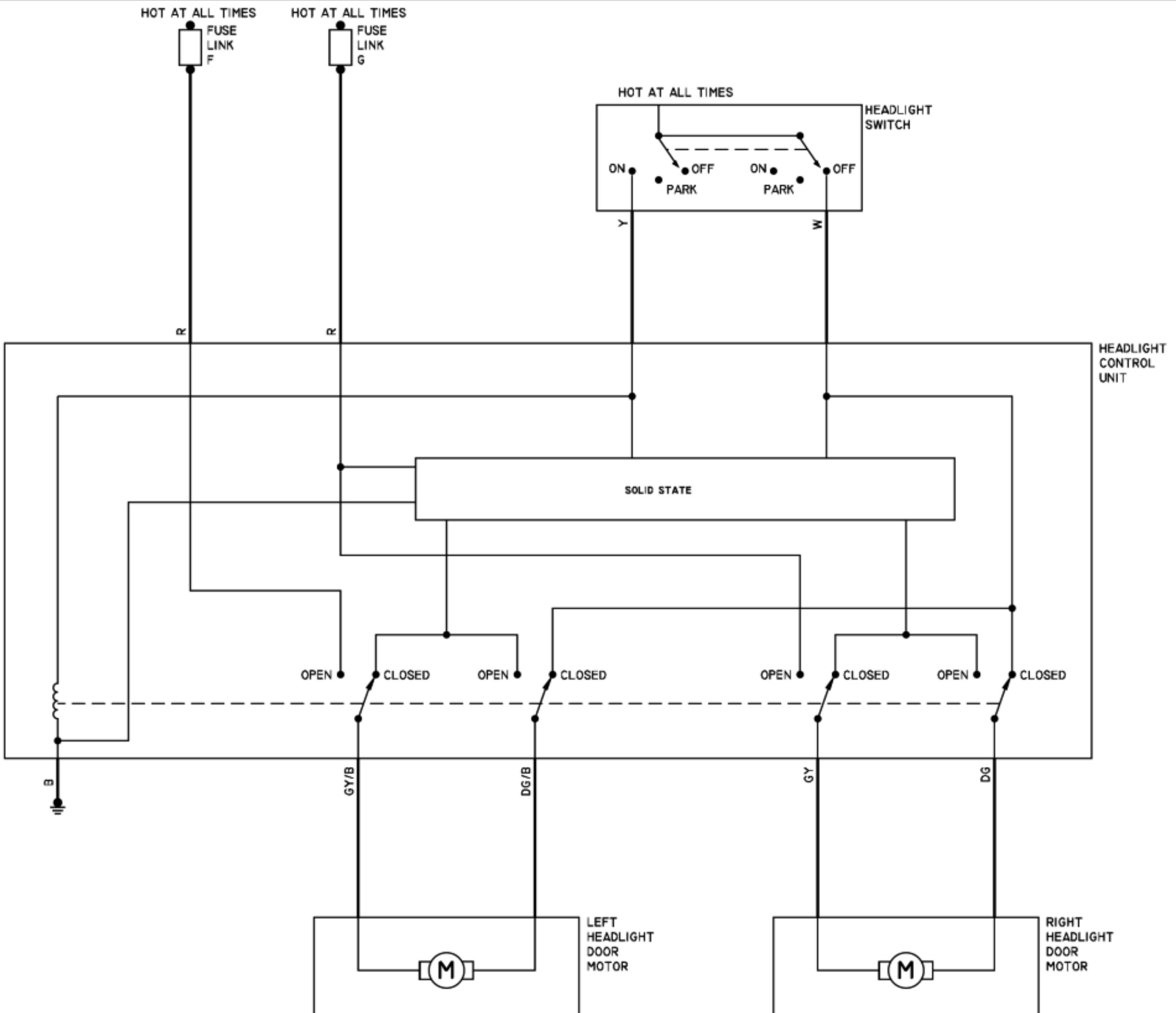
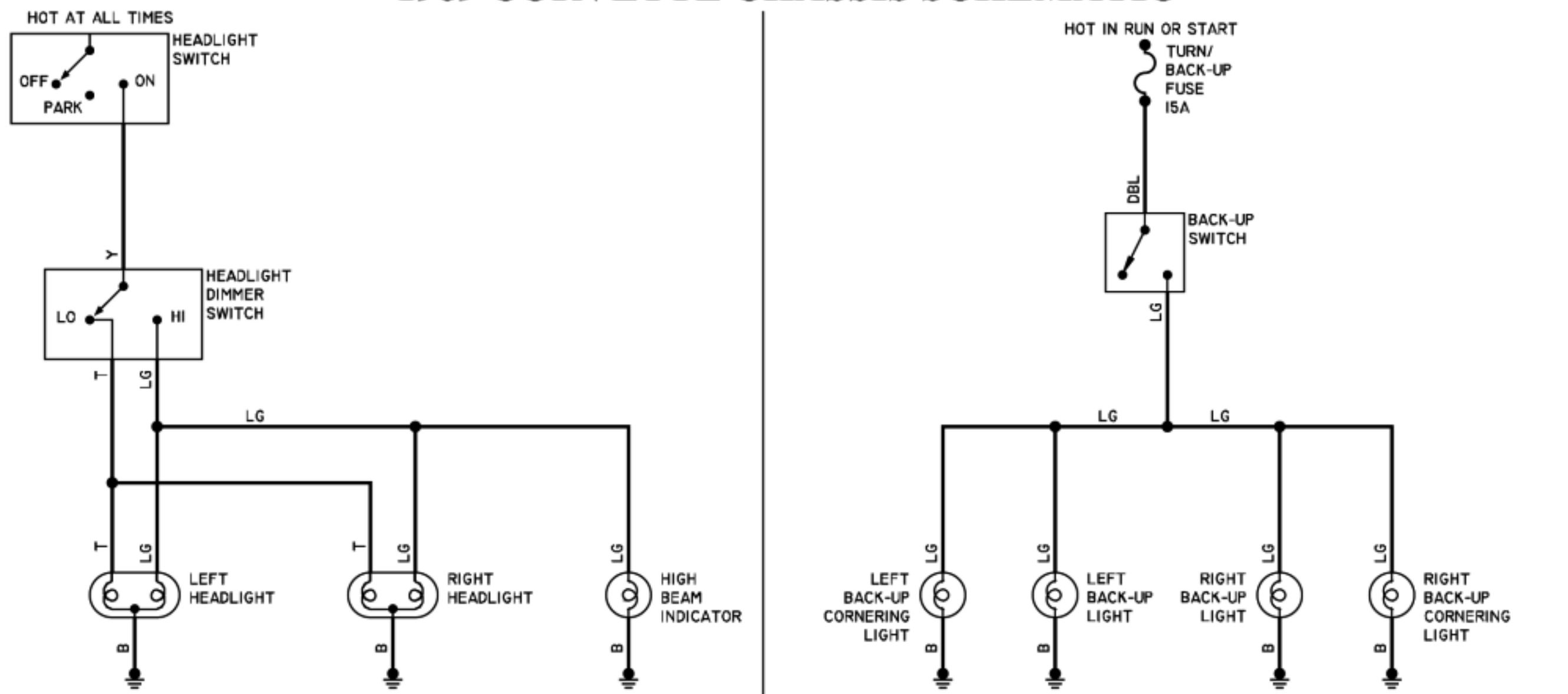

DIAGRAM 17

1984-85 CORVETTE CHASSIS SCHEMATIC

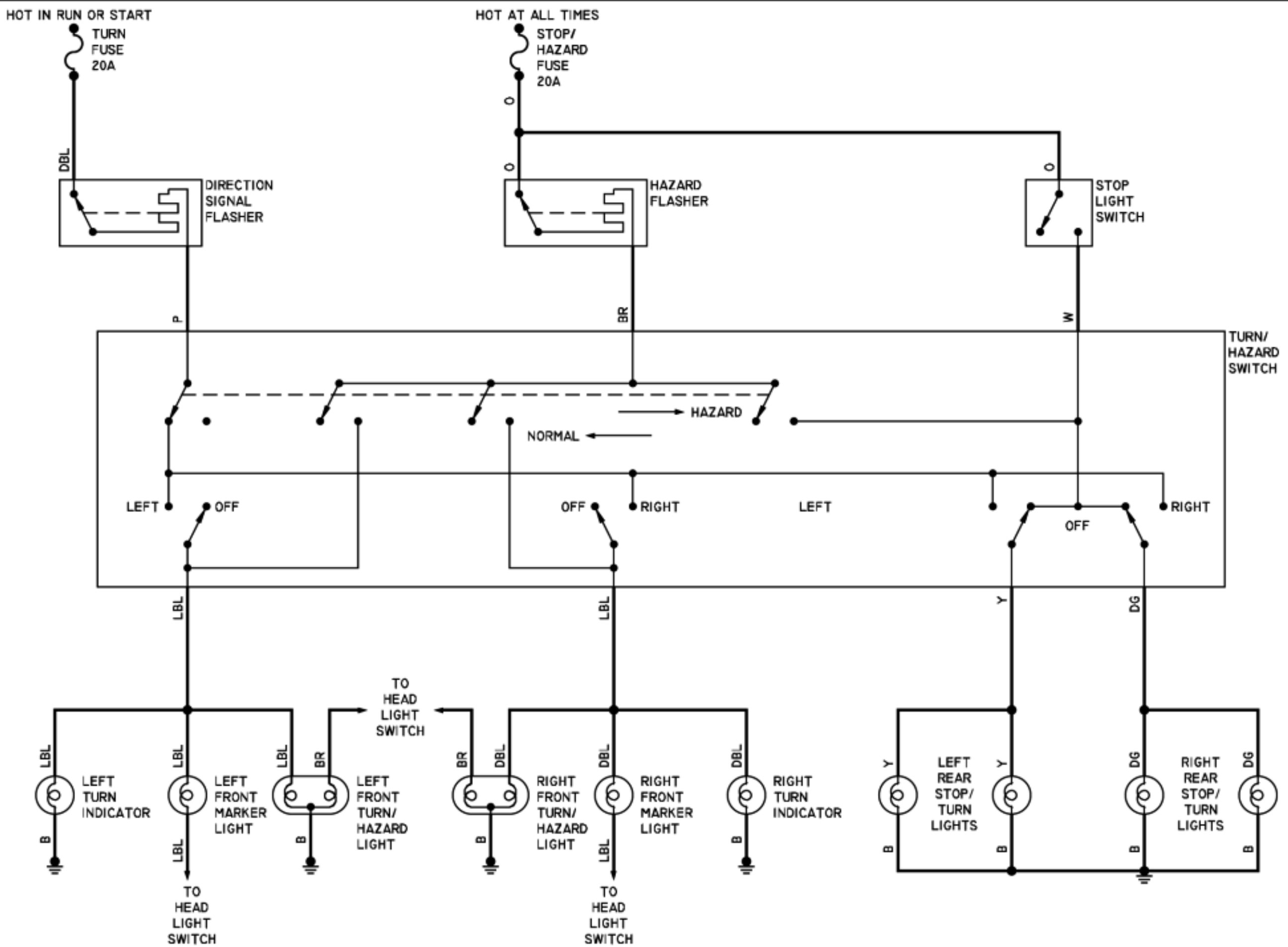
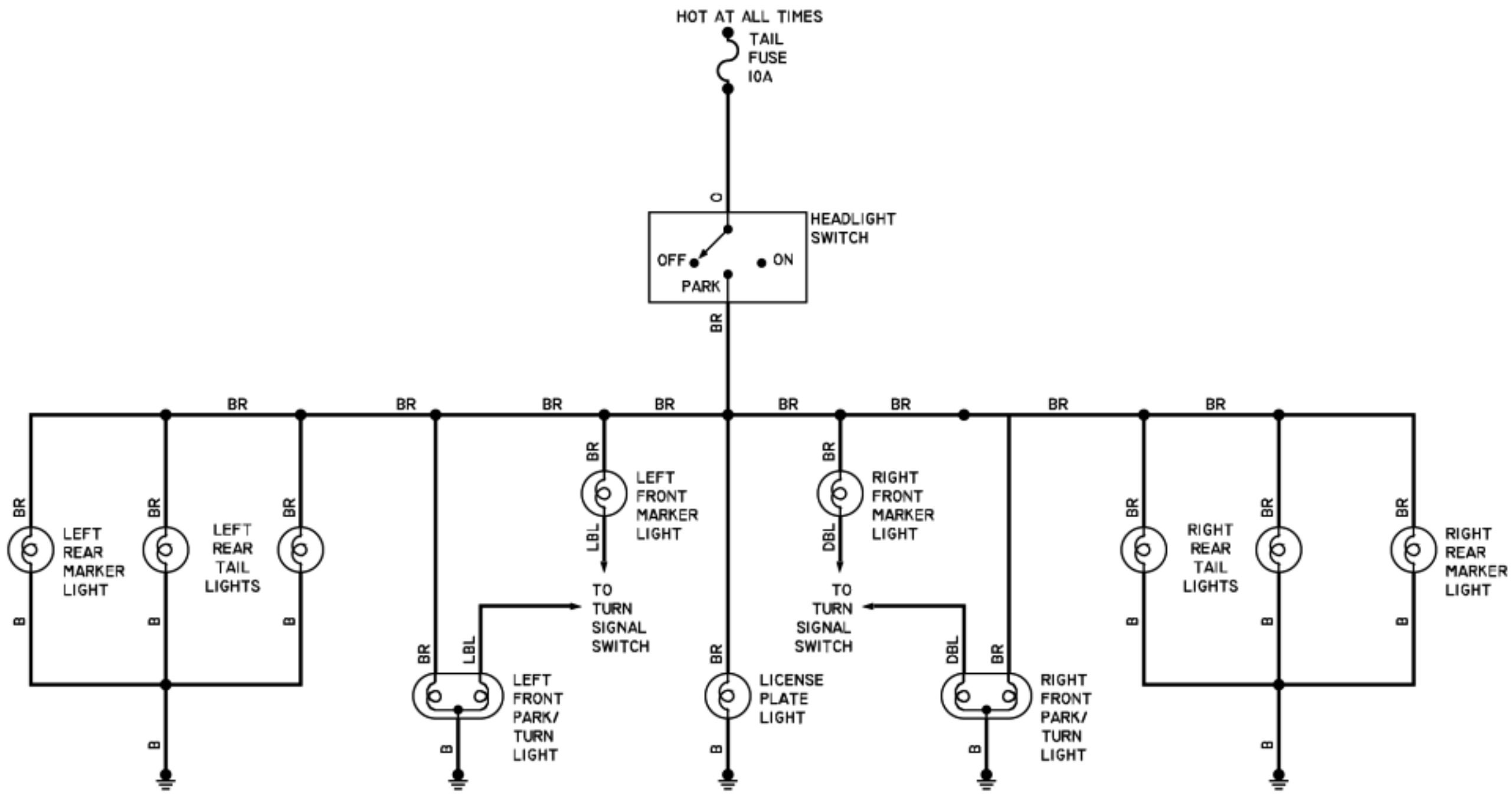

DIAGRAM 18

1986-89 CORVETTE CHASSIS SCHEMATIC

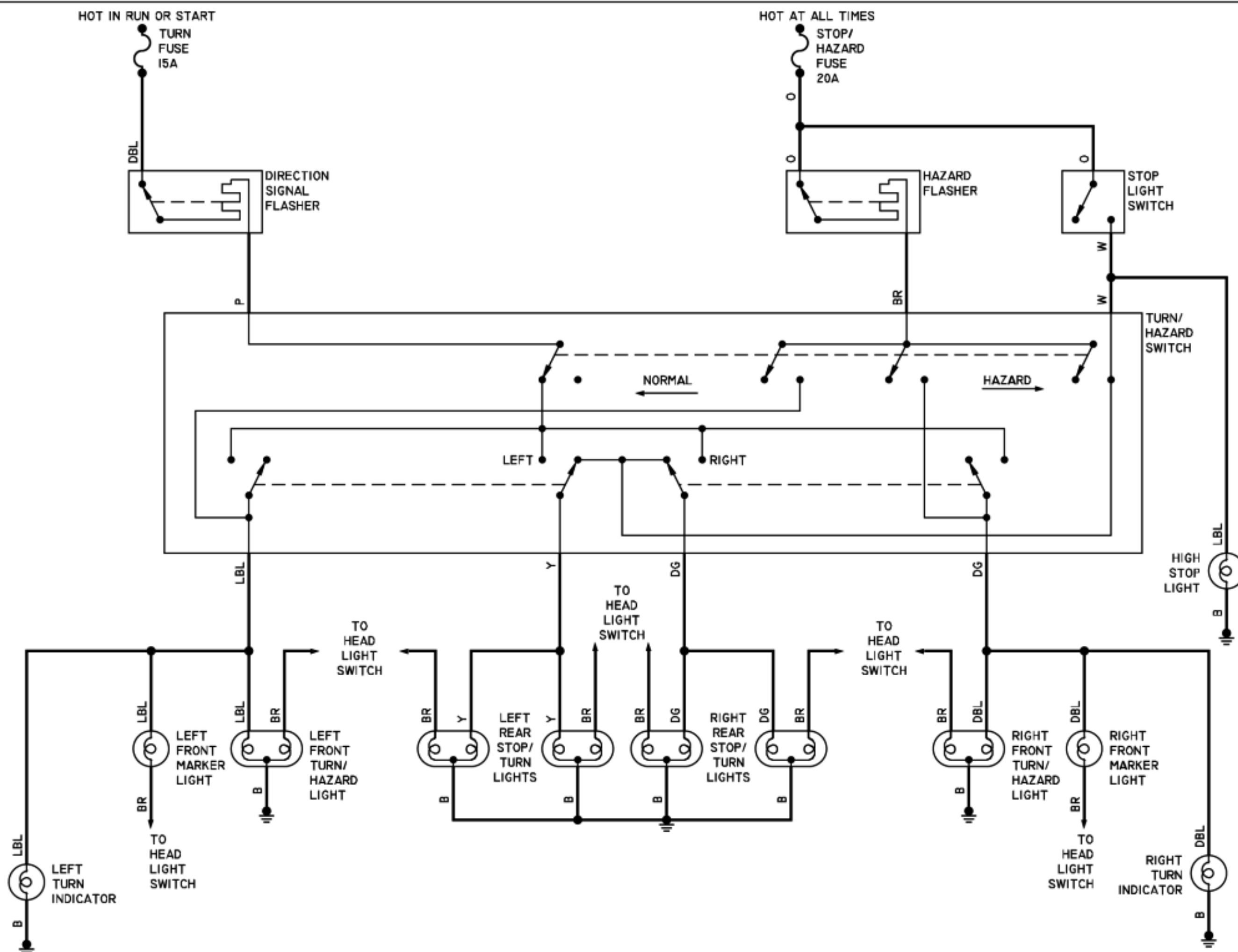
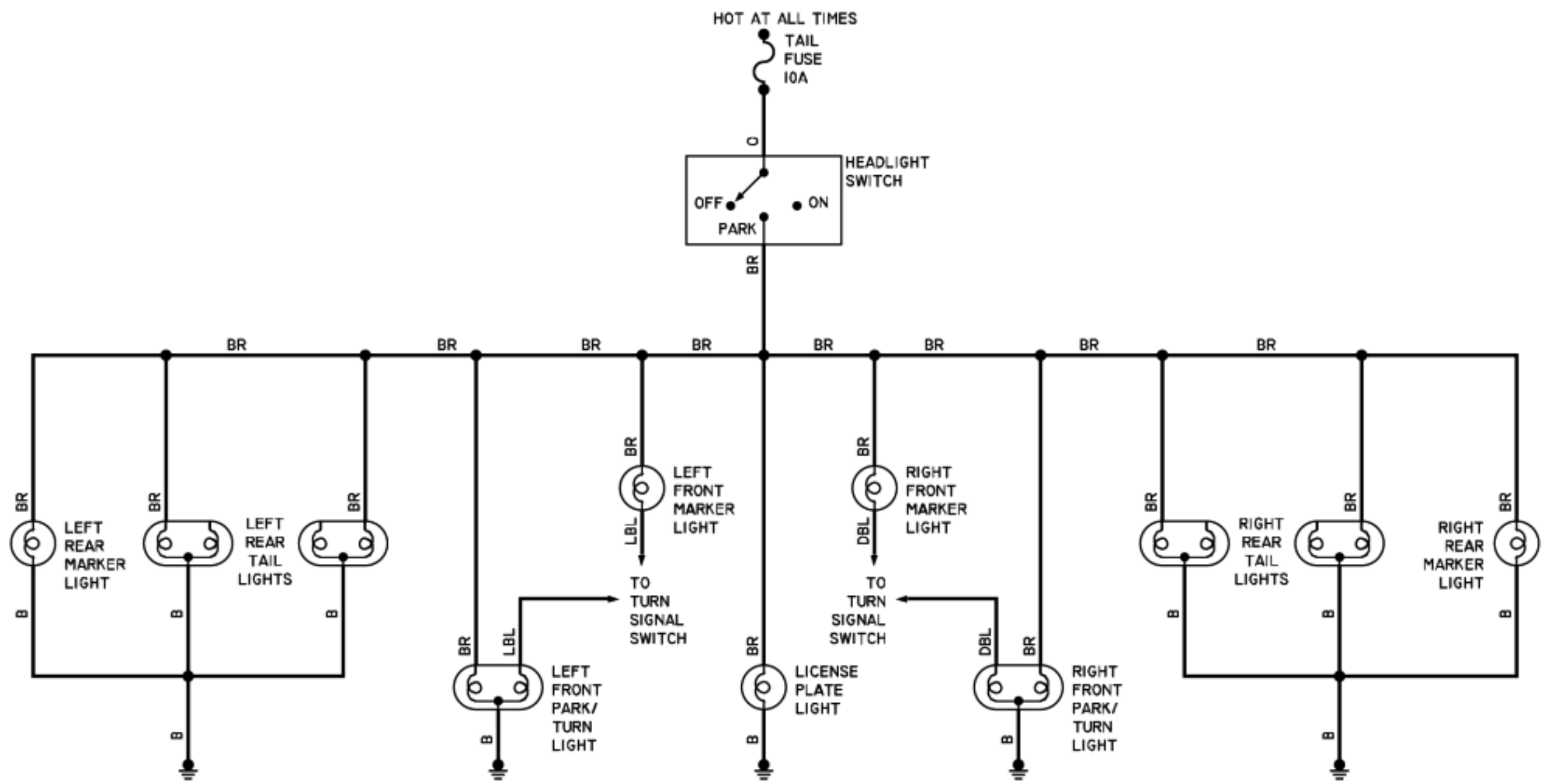

DIAGRAM 19

1990-96 CORVETTE CHASSIS SCHEMATIC

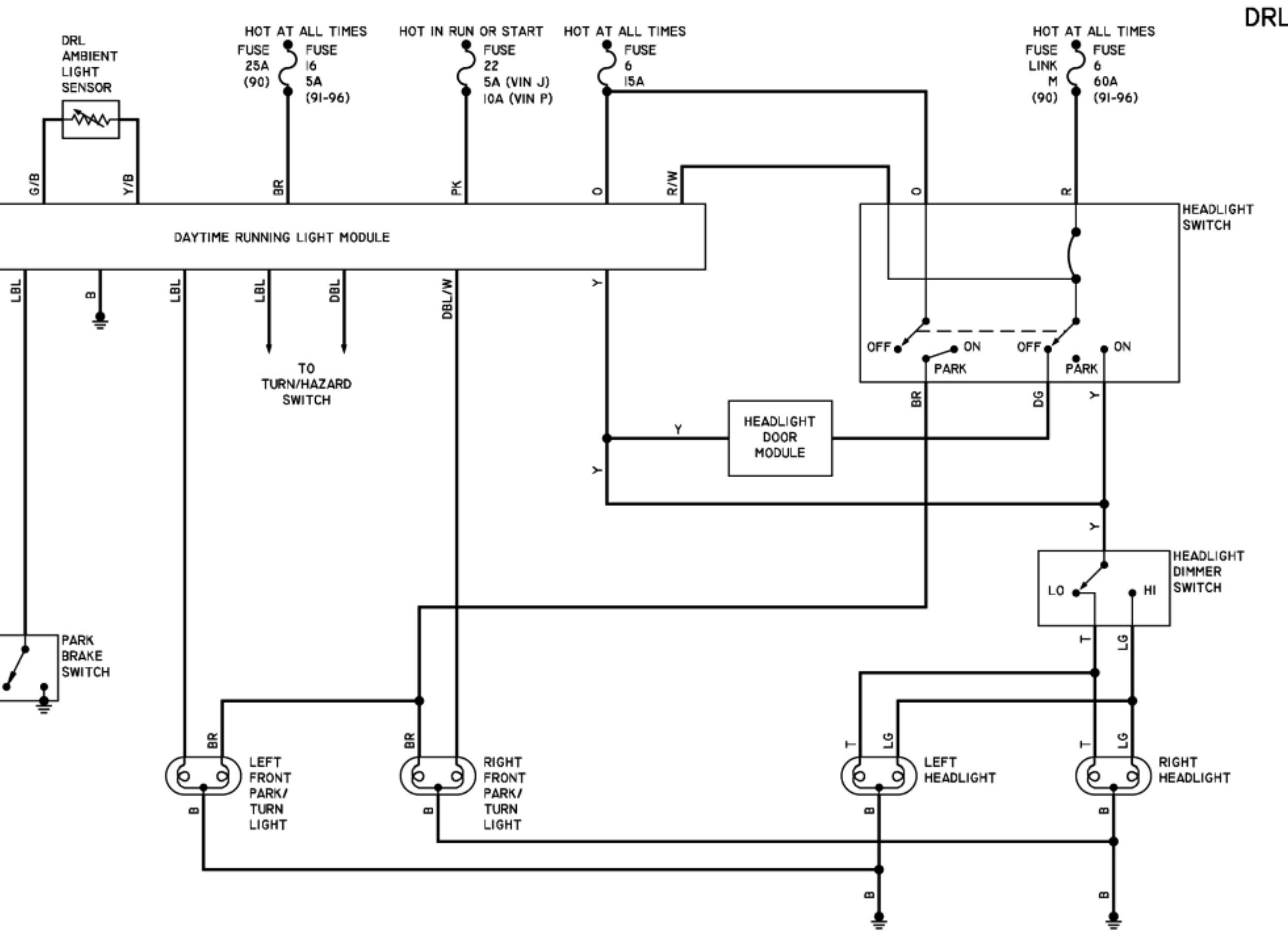
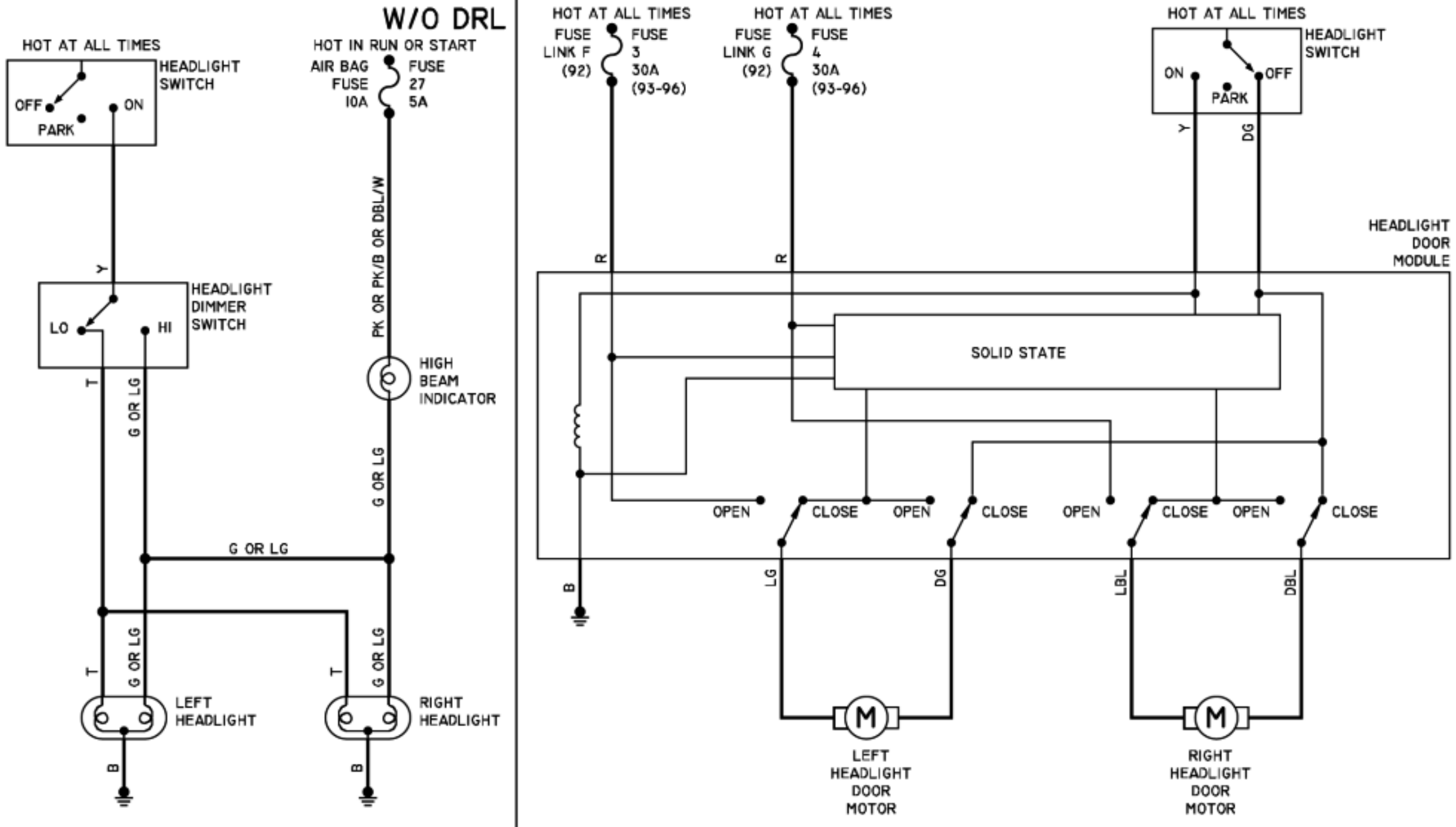

DIAGRAM 20

1990-96 CORVETTE CHASSIS SCHEMATIC

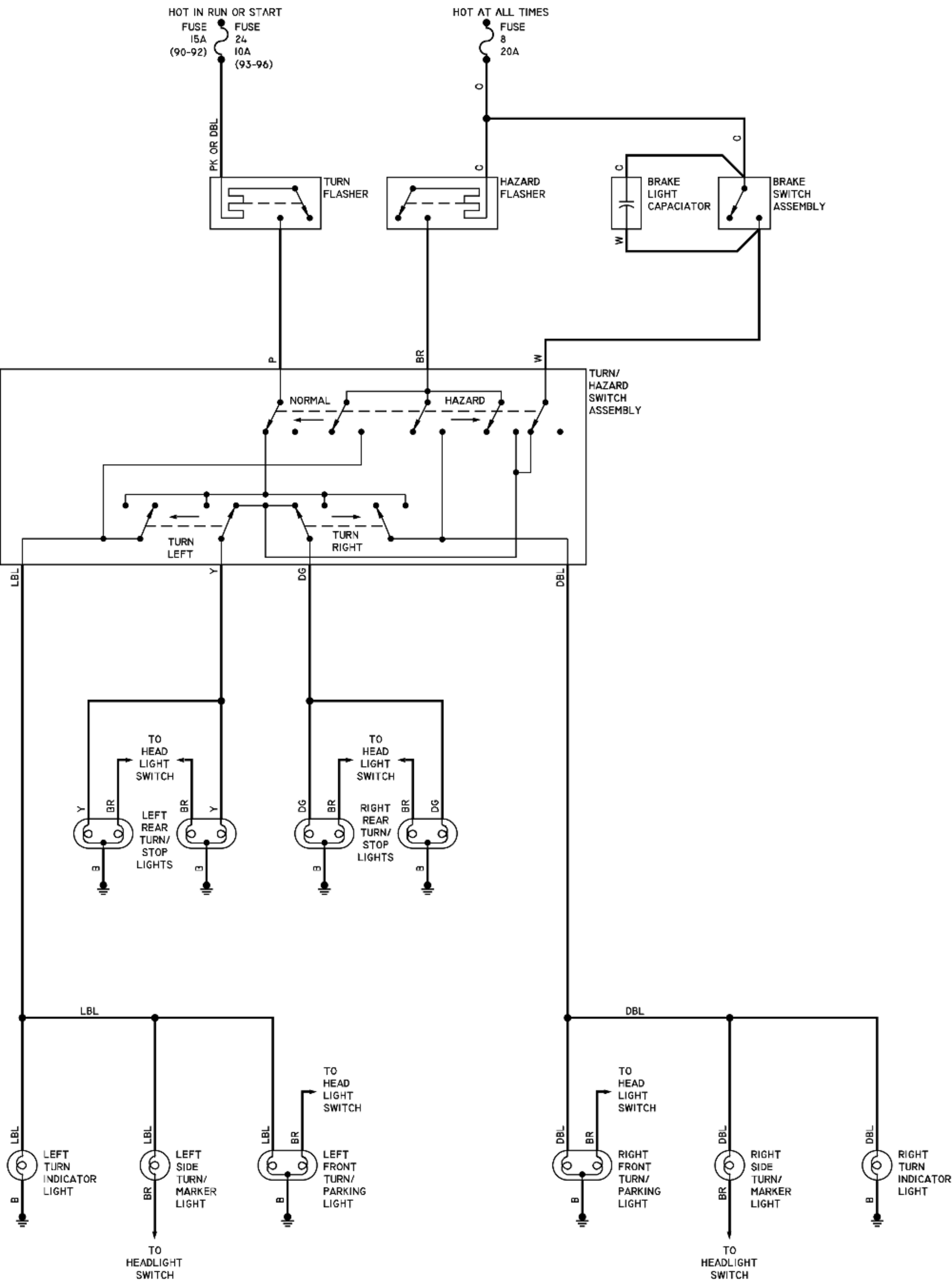
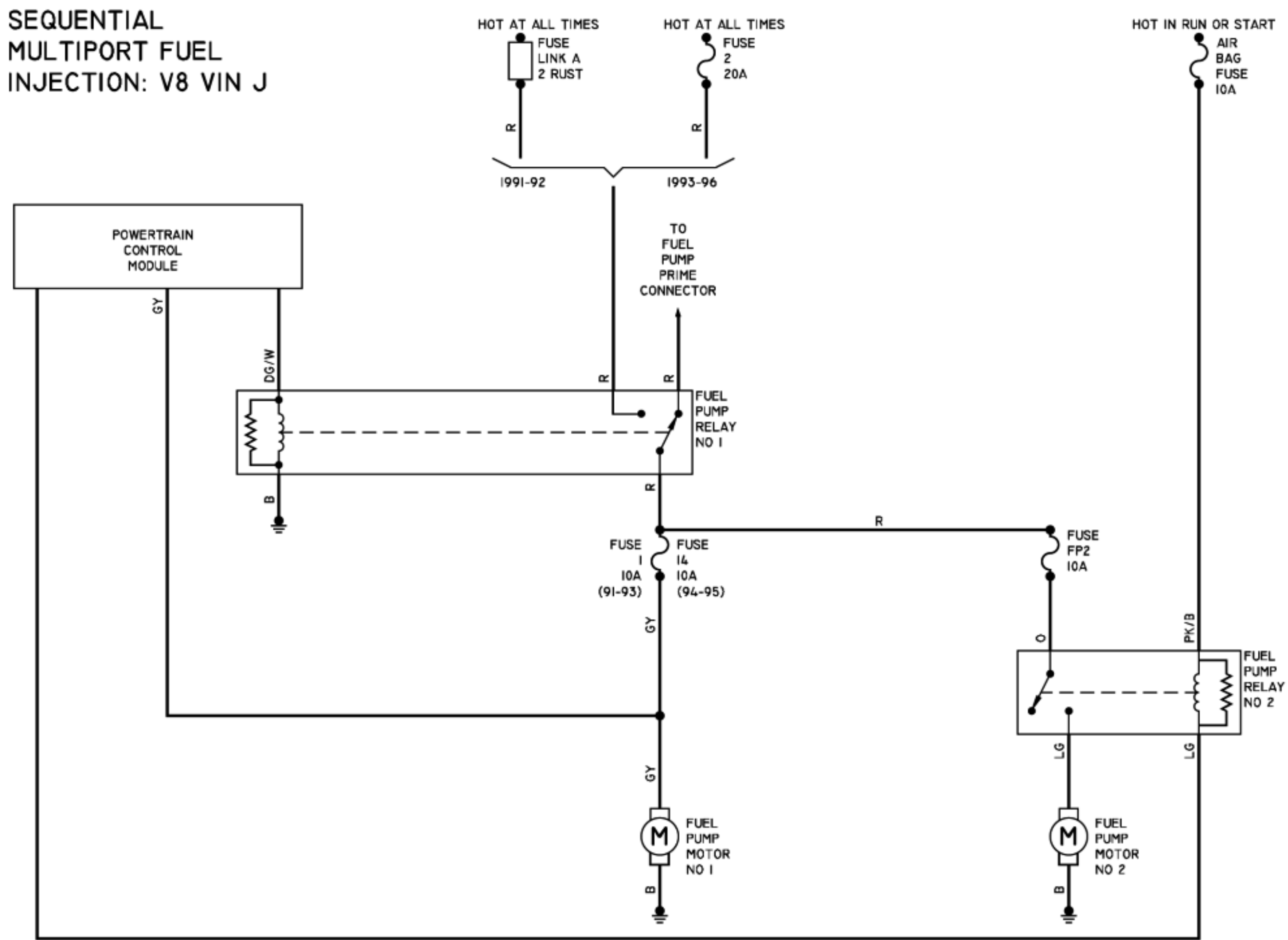

DIAGRAM 21

1990-96 CORVETTE CHASSIS SCHEMATIC

SEQUENTIAL MULTIPOINT FUEL INJECTION: V8 VIN J



MULTIPOINT FUEL INJECTION: V8 VIN P (92-96) VIN 8 (90-91)

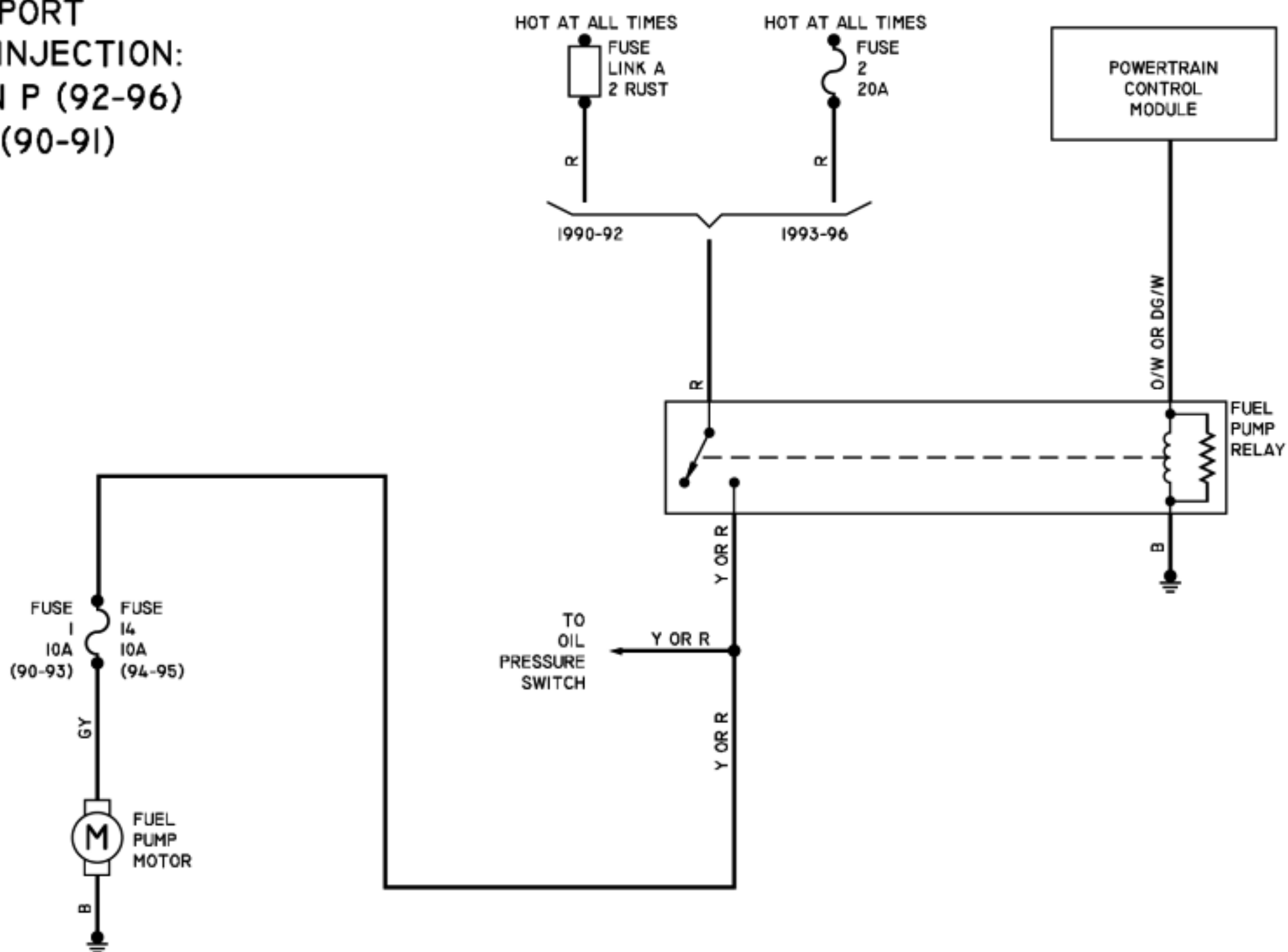

DIAGRAM 23

1990-96 CORVETTE CHASSIS SCHEMATIC

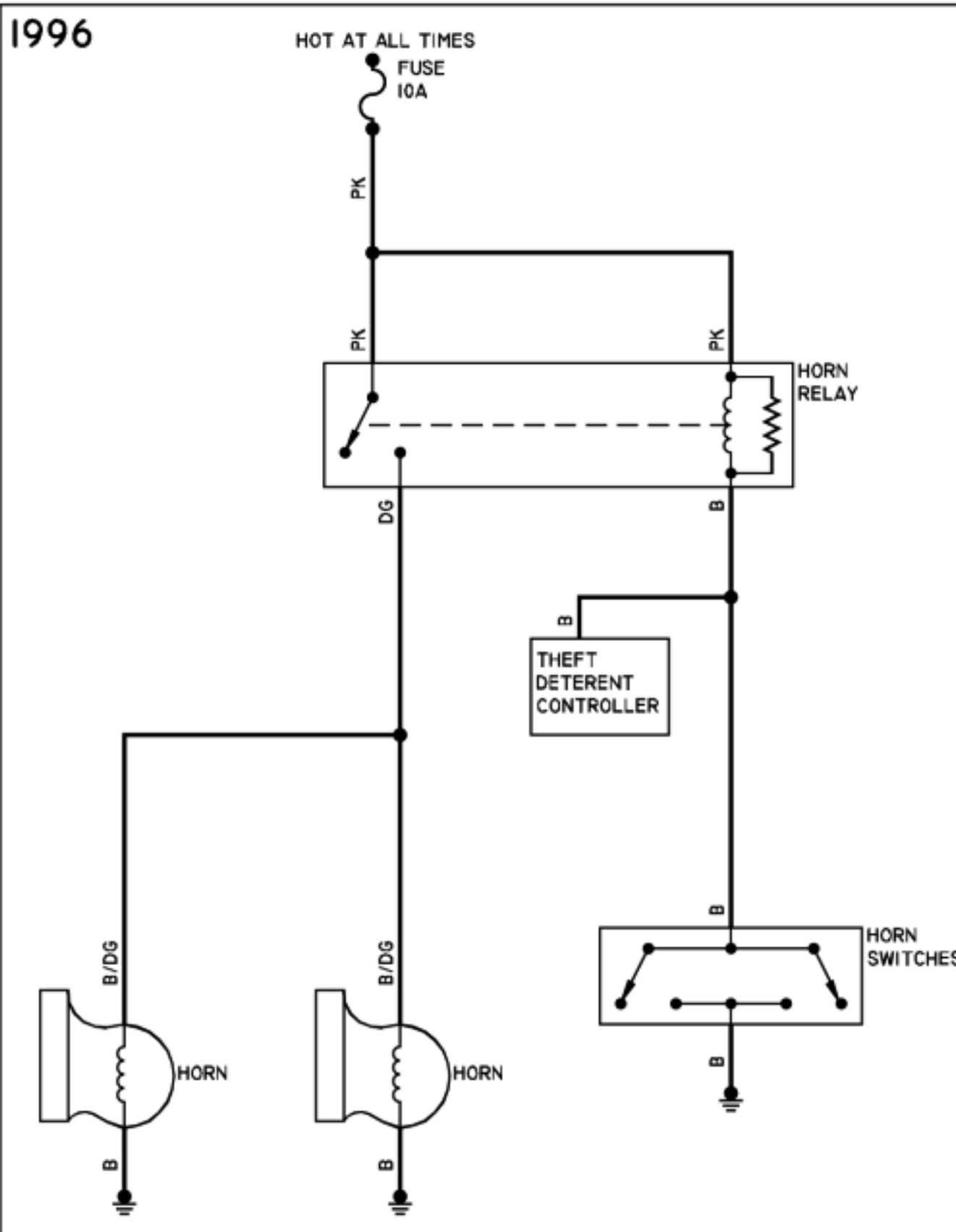
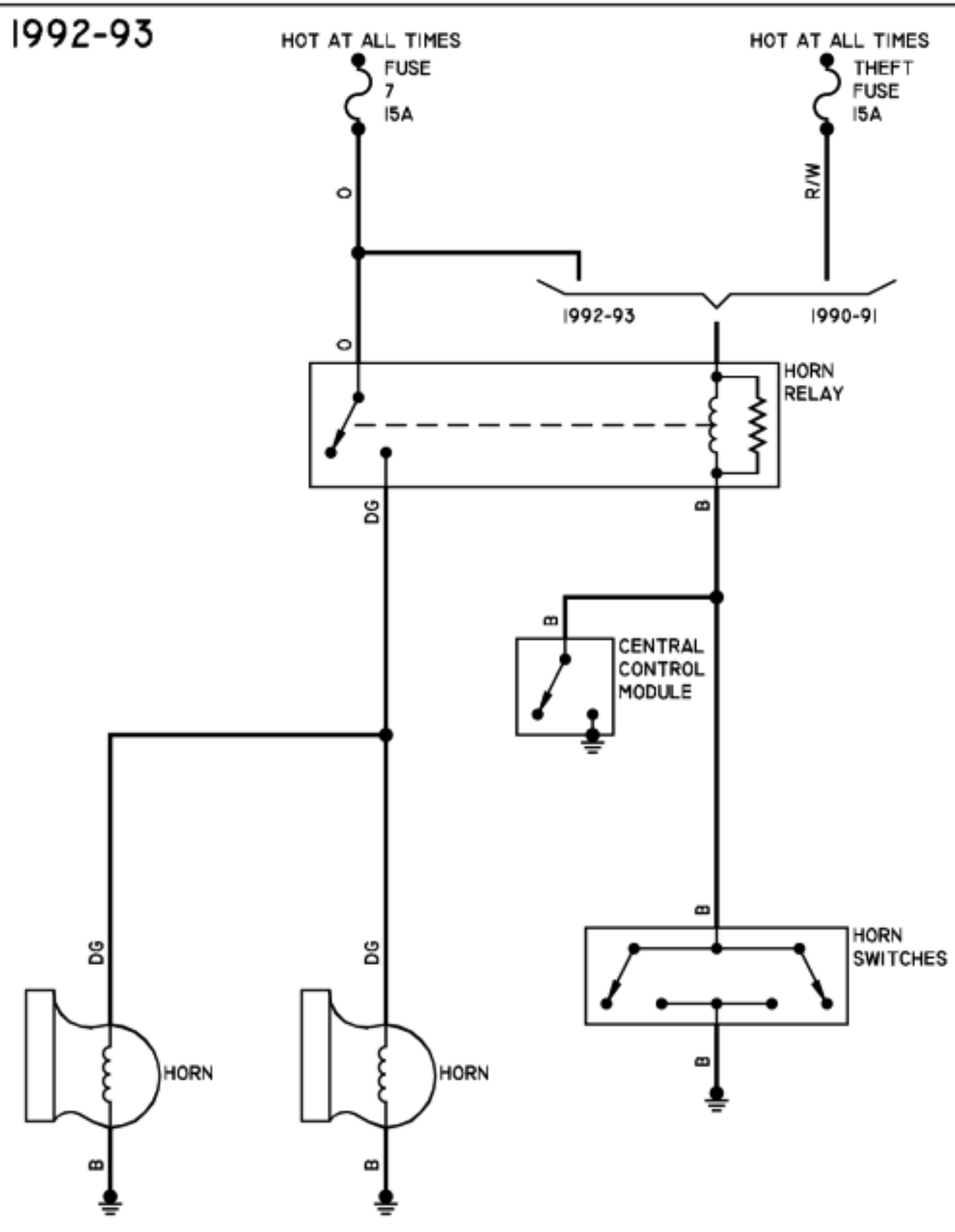
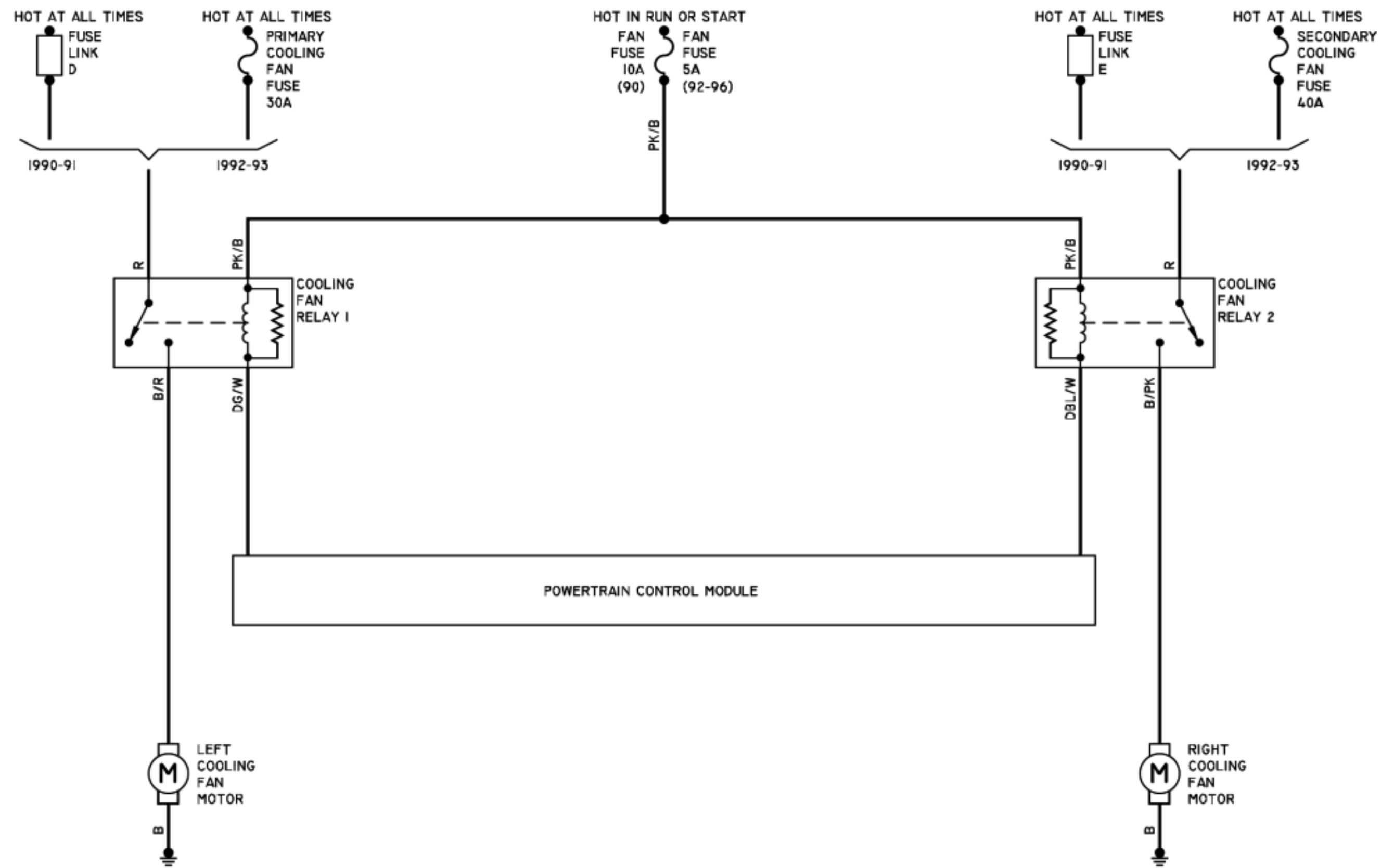

DIAGRAM 24

1994-95 CORVETTE CHASSIS SCHEMATIC

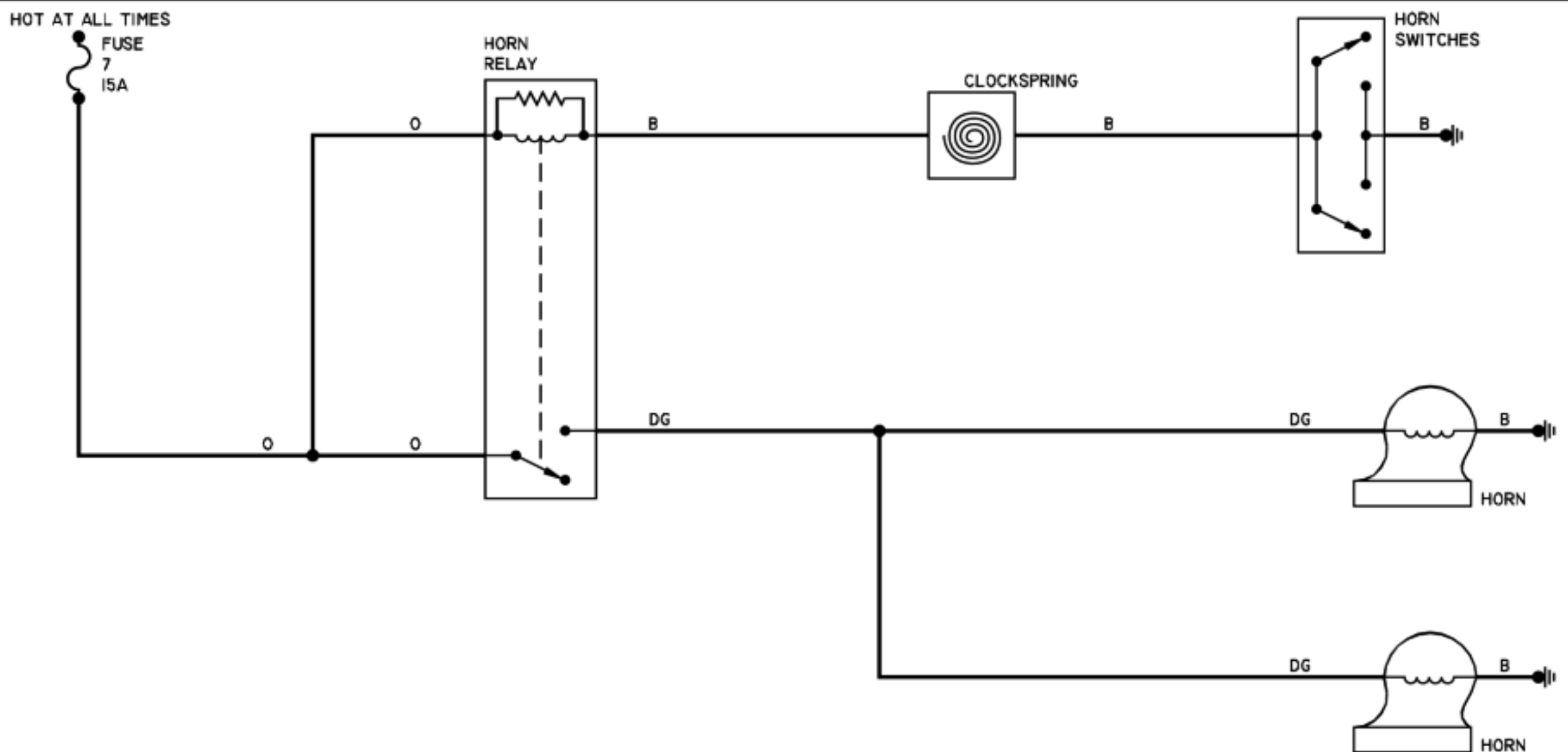
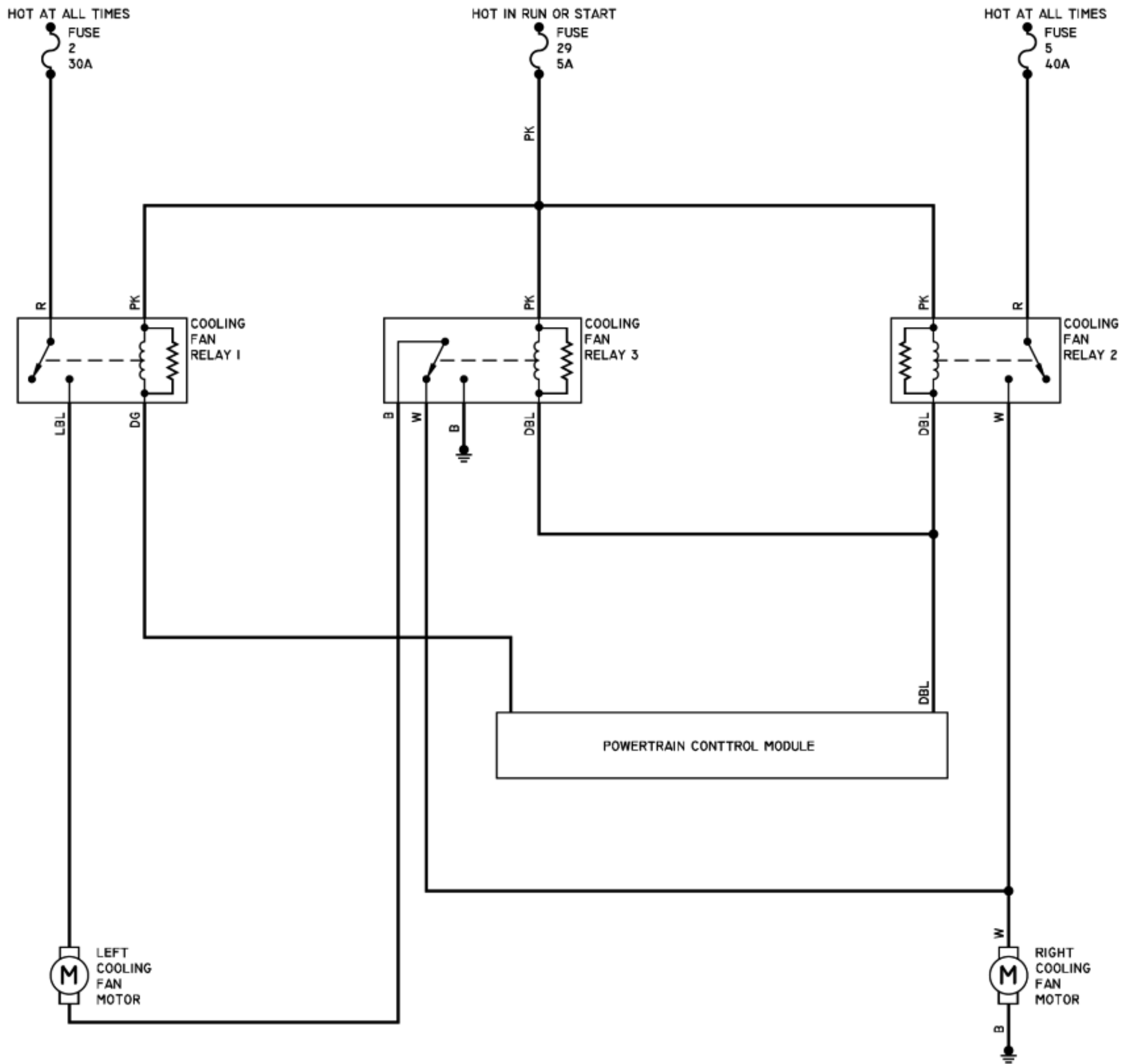

DIAGRAM 25

1984-96 CORVETTE CHASSIS SCHEMATIC

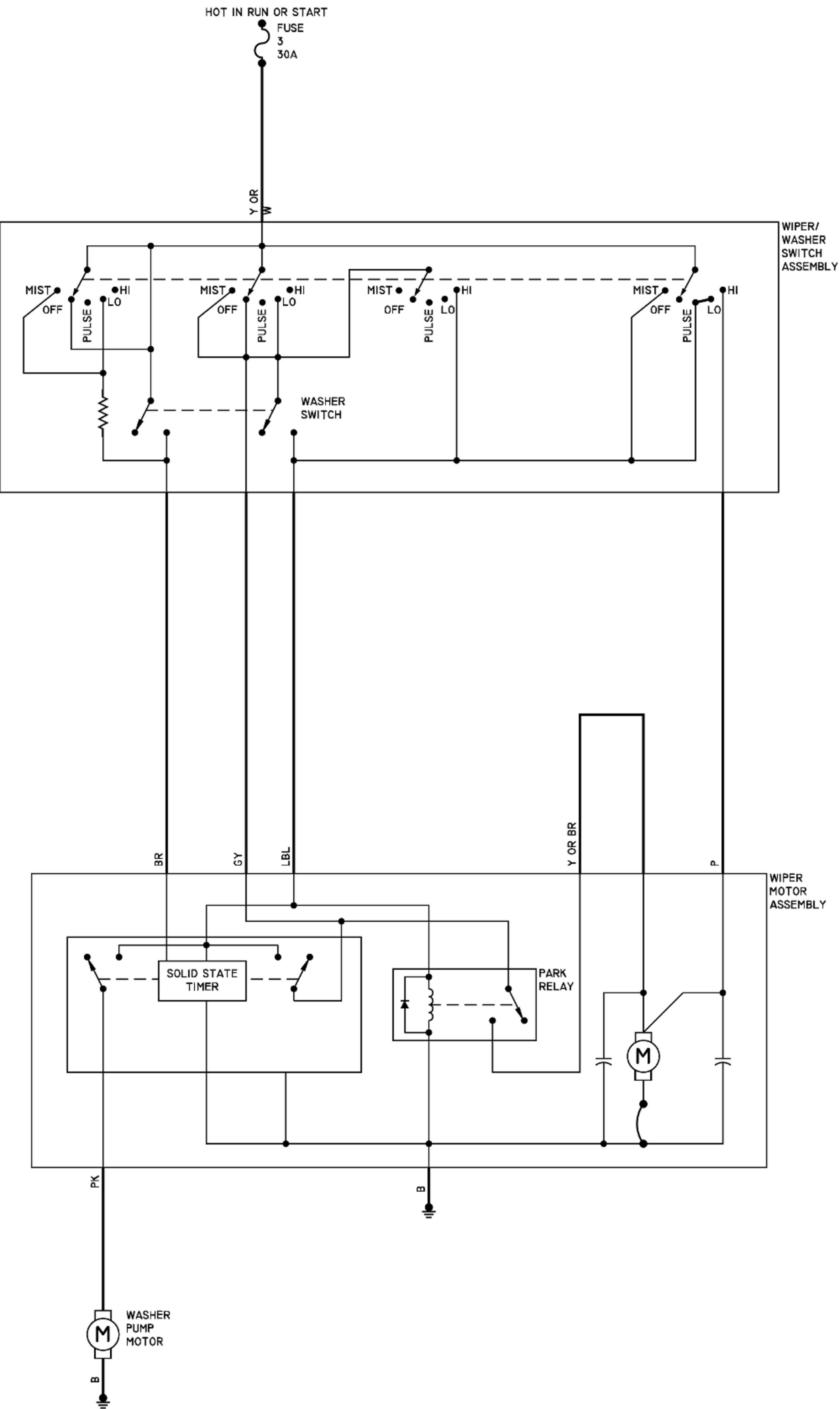

DIAGRAM 26